

How to Obtain Service (U.S.A. Only)

We back your investment in quality products with quick, expert service and genuine Lowrance® replacement parts. If you're in the United States and you have questions, please contact the Factory Customer Service Department using our toll-free number listed below. You must send the unit to the factory for warranty service or repair. Please call the factory before sending the unit. You will be asked for your unit's serial number. Use the following toll-free number:

800-324-1356

Your unit is covered by a full one-year warranty. (See inside for complete warranty details.) If your unit fails and the failure is not covered by the original warranty, Lowrance has a flat-rate repair policy that covers your unit and accessories packed with the unit at the factory. There is a 180-day warranty on all non-warranty repairs from the factory, which is similar to the original warranty, but is for 180 days rather than one year. For further details, please call us at the above number.

Remember, non-warranty repairs are subject to Lowrance's published flat-rate charges and 180-day warranty.

Shipping Information

When sending a product for repair, we recommend you do the following:

1. Always use the original shipping container and filler material the product was packed in when shipping your product.
2. Always insure the parcel against damage or loss during shipment. Lowrance does not assume responsibility for goods lost or damaged in transit.
3. For proper testing, repair, and service, send a brief note with the product describing the problem. Be sure to include your name, return shipping address, and a daytime telephone number.

Lowrance Electronics may find it necessary to change or end our shipping policies, regulations, and special offers at any time. We reserve the right to do so without notice.

Accessory Ordering Information

To order accessories such as power cables or transducers, please contact:

- 1) Your local marine dealer. Most quality dealers that handle marine electronic equipment should be able to assist you with these items. Consult your local telephone directory for listings.

- 2) LEI Extras, Inc. P.O. Box 129 Catoosa, OK 74015-0129
or call 1-800-324-0045 USA only

LITHO IN U.S.A.

988-0133-16

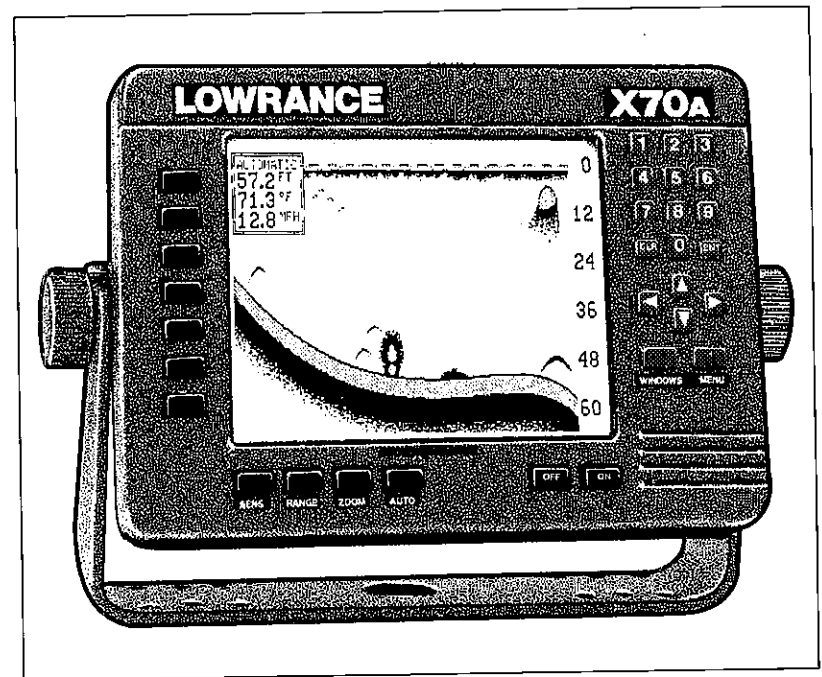

X-70A

INSTALLATION AND OPERATION INSTRUCTIONS

LOWRANCE ELECTRONICS, INC.
12000 E. SKELLY DR., TULSA, OK 74128

TOOLS YOU WILL NEED:

TRANSOM MOUNT TRANSDUCER INSTALLATION:

Hand-held Drill with a variety of small bits
Four stainless steel screws (to attach X-70A's bracket to the dash.)
Marine grade caulking compound (to seal transducer mounting screws)

SHOOT-THRU-HULL MOUNT:

100 grit sandpaper
One package of the either of the following epoxies:
Power Poxy®, 1 oz package. Made by: Power Poxy® Adhesives, Inc. or
True Value® brand TRUE BOND epoxy or PLASTIC WELDER™ epoxy
sold by True Value® stores or
Devcon® brand PLASTIC WELDER™ epoxy.

NOTICE!

The storage temperature for your unit is from -4 degrees to +167 degrees Fahrenheit (-20 degrees to +75 degrees Celcius). Extended storage in temperatures higher or lower than specified will damage the liquid crystal display in your unit. This type of damage is not covered by the warranty. For more information, contact the factory's Customer Service Department or your local service center.

How to Obtain Service

(Canadian Customers Only)

We back your investment in quality products with quick, expert service and genuine Lowrance replacement parts. If you need service or repairs, contact the Lowrance Factory Customer Service Department at the toll-free number listed below. A technician may be able to solve the problem and save you the inconvenience of returning your unit. You will be asked for your unit's serial number.

800-347-1014

Canada Only. Monday through Friday 8:00 A.M. - 8:00 P.M. Central Time.

How to Obtain Service

(International Customers Only)

If you need service or repairs, contact the dealer in the country you purchased your unit.

**WARRANTY REPAIR WILL BE HONORED ONLY IN THE COUNTRY
UNIT WAS PURCHASED.**

Please follow the shipping instructions shown below on this page if you have to mail your unit to the dealer. For proper testing, repair, and service, send a brief note with the product describing the problem. Be sure to include your name, return shipping address, and a daytime telephone number.

Shipping Information

When sending a product for repair, please do the following:

1. Always use the original shipping container and filler material the product was packed in when shipping your product.
2. Always insure the parcel against damage or loss during shipment. Lowrance does not assume responsibility for goods lost or damaged in transit.
3. For proper testing, repair, and service, send a brief note with the product describing the problem. Be sure to include your name, return shipping address, and a daytime telephone number.

Accessory Ordering Information

To order accessories such as power cables or transducers, please contact:

1. Your local marine dealer. Most quality dealers that handle marine electronic equipment should be able to assist you with these items. Consult your local telephone directory for listings.
2. Canadian customers only can write:
Lowrance/Eagle Canada, 919 Matheson Blvd., E. Mississauga, Ontario L4W2R7
or fax 416-629-3118

TABLE OF CONTENTS

INTRODUCTION	1
MOUNTING	1
POWER CONNECTIONS	3
TRANSDUCER	4
KEYBOARD BASICS	11
DISPLAY	12
MENUS	13
HELP	13
WINDOWS	13
VIEWING WINDOWS OPTIONS	15
MODIFYING GROUPS	15
RESETTING ALL GROUPS	16
SONAR OPERATION	17
AUTOMATIC	17
SENSITIVITY	18
RANGE	19
ZOOM - Automatic Operation	20
ZOOM - Manual Operation	21
MENU - PAGE 1	25
CHART SPEED	25
GRAYLINE®	25
FISH I.D.	26
FISHTRACK™	27
DISPLAY CONTRAST	27
MENU - PAGE 2	28
ADJUST BACK LIGHT LEVEL	28
BACK LIGHT ON/OFF	28
SPEAKER VOLUME	28
TURN DIGITAL BOX OFF	29
CONSTRUCT DIGITAL BOX	29
MENU - PAGE 3	30
DISPLAY ZOOM BAR	30
DISPLAY ZONE BAR	30
DIGITAL SONAR	31
DEPTH LINES	31
CHART CURSOR	31
MENU - PAGE 4	32
FASTRAK	32
SELECT UNITS OF MEASURE	33
CLEAR DISTANCE LOG	33
MENU - PAGE 5	34
ADJUST CHART SURFACE CLARITY	34
ADVANCED SIGNAL PROCESSING (ASP)	34
SYSTEM INFORMATION	35
TRANSDUCERS AND CONE ANGLES	36
FISH ARCHES	37
SONAR TROUBLESHOOTING	38
WINDOWS SUMMARY	41
WARRANTY	43
MISSING PARTS	46
INTERNATIONAL SERVICE INFORMATION	47

Copyright © 1994 Lowrance Electronics
All rights reserved.

All features and specifications subject to change without notice.
All screens in this manual are simulated.

INTRODUCTION

The X-70A is a high quality, wide screen sonar with performance that is second to none in its class. Using menu features and "soft-key" operation, the X-70A is also one of the easiest-to-use sonars that Lowrance has ever built. The wide "ClearVision" screen shows the underwater world with high resolution and detail. The display and keyboard are also lighted for night operation. The X-70A also has digital depth, boat speed, surface water temperature, and distance travelled (log) displays (requires an optional ST-T speed/temperature sensor).

Read this manual and take it with you the first few times you use your unit. It makes a great reference if you need it.

MOUNTING - Bracket Mount

The X-70A can be mounted on its gimbal bracket or in-dash mounted. Brackets are supplied for both configurations, however if the dash is thicker than 1/2", a special bracket will have to be purchased to mount the unit in the dash. You can install the X-70A on its bracket in any convenient location, provided there is clearance behind the unit when it is tilted for the best viewing angle. Holes in the bracket base allow wood screw or through-bolt mounting. You may need to place a piece of plywood on the back of thin fiberglass panels to secure the mounting hardware. Make certain there is enough room behind the unit to attach the power and transducer cables.

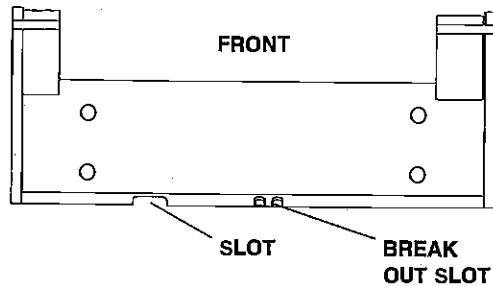

You will need to drill a hole in the dash for the power and transducer cables. The smallest hole that will pass one power or transducer plug is one inch. After the hole is drilled, pass the transducer connector up through the hole first, then pass the power cable down through it.

After the cables have been routed, fill the hole with a good marine sealing compound. Offset the bracket to cover the hole. Route the power cable through the slot and break out one of the other slots in the bracket for the transducer cable.

NOTICE!

Please check the items in the box against this list. You should have all of the items shown on this page. If you are missing any of the items, please call our special toll-free number:

1-800-324-1353

A RECORDED MESSAGE will request the following information. Please have it ready before you call.

1. Your name, shipping address, and telephone number.
2. The part that's missing.
3. The model, serial number, and DATE AND PLACE OF PURCHASE OF YOUR UNIT.
4. The best time of day to call you if we have questions.

Provided that all of the requested information is recorded and approved by our Customer Service Department, the missing item(s) will be shipped directly to you free of charge.

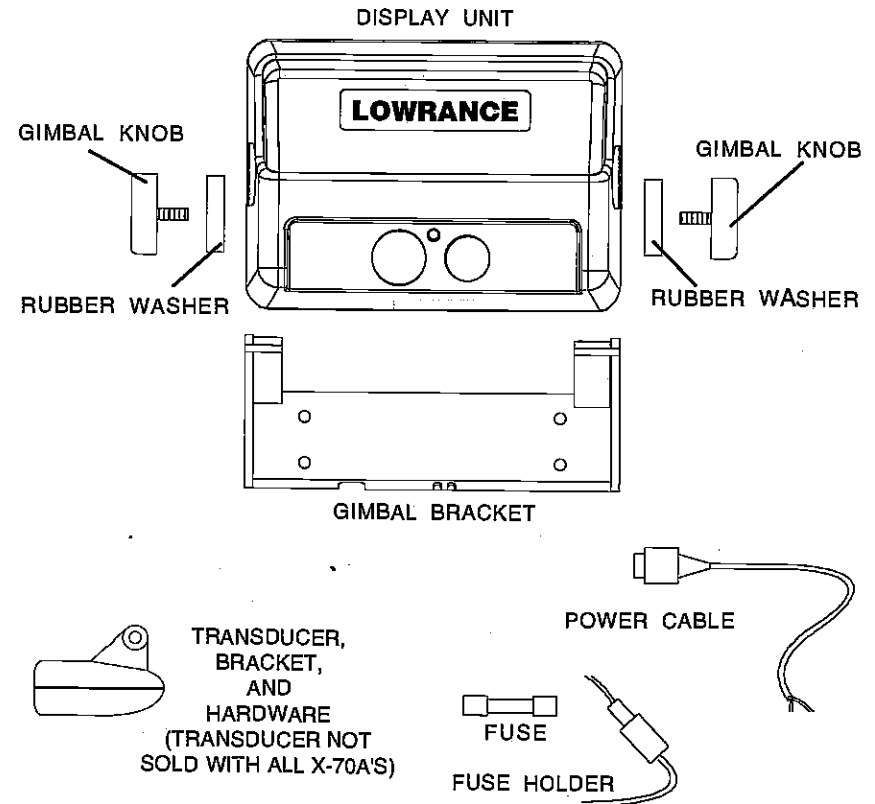

Notes:

IN-DASH MOUNTING

The X-70A can be installed in the dash with the supplied hardware if the dash is 1/2" thick or less. Determining the dash thickness can be difficult, however, if you remove a gauge from the dash, you can easily measure the thickness. Try this in an area that's close to the location that you wish to install the unit, since the thickness can vary significantly in some boats. Make certain there is clearance behind the dash for the unit and there is enough room to tighten the bolts on both sides of the unit.

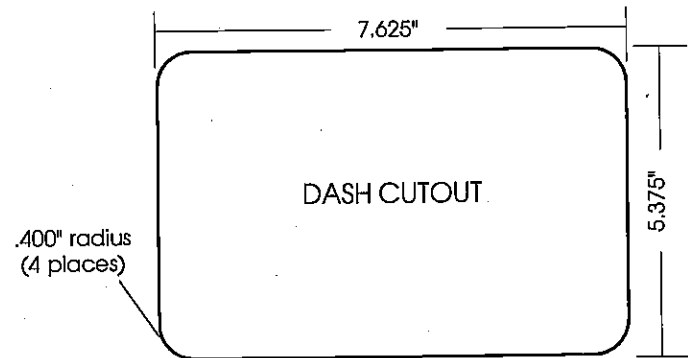

Once you've determined the location for the unit, cut the hole according to the drawing shown above. Measure carefully before cutting! After cutting the dash, place the gasket supplied with the X-70A around the unit and place the unit in the hole.

Supplied with the X-70A are rubber pads, bolts, washers, and cam clamps to attach the X-70A to the dash. Peel the adhesive backing off the rubber pads and place one on each side of the X-70A in the location where the cam clamp will touch the back side of the dash. Using the hardware supplied with the unit, attach the X-70A to the dash. Make certain that the cam clamp on the left side of the unit is pointing down and the cam clamp on the right side of the unit is pointing up before you start tightening the bolts.

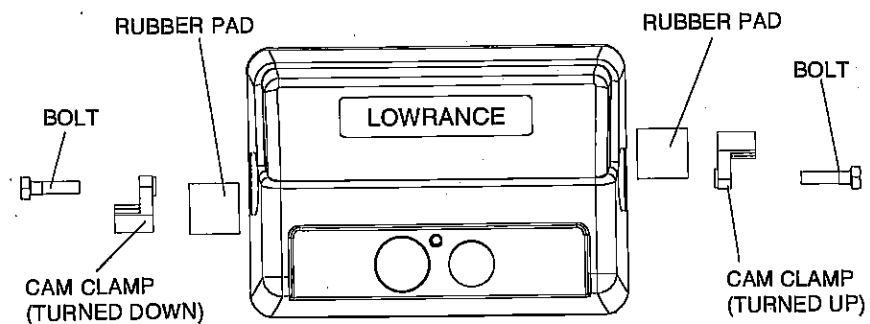

POWER CONNECTIONS

The X-70A works from a twelve-volt battery system. For the best results, attach the power cable directly to the battery. You can attach the power cable to an accessory or power buss, however you may have problems with electrical interference. Therefore, it's safer to go ahead and attach the power cable directly to the battery. If the cable is not long enough, splice #18 gauge wire onto it. The power cable has two wires, red and black. Red is the positive lead, black is negative or ground. Make certain to attach the in-line fuse holder to the red lead as close to the power source as possible. For example, if you have to extend the power cable to the battery or power buss, attach one end of the fuse holder directly to the battery or power buss. This will protect both the unit and the power cable in the event of a short. The X-70A uses a 3-amp fuse.

IMPORTANT!

Do not use this product without a 3-amp fuse wired into the power cable! Failure to use a 3-amp fuse will void your warranty.

If you're installing an optional speed/temperature sensor, read the speed/temperature sensor's installation manual for mounting instructions. Route the sensor's cable to the X-70A's power cable and plug it into the connector marked "SPEED/TEMP CABLE"

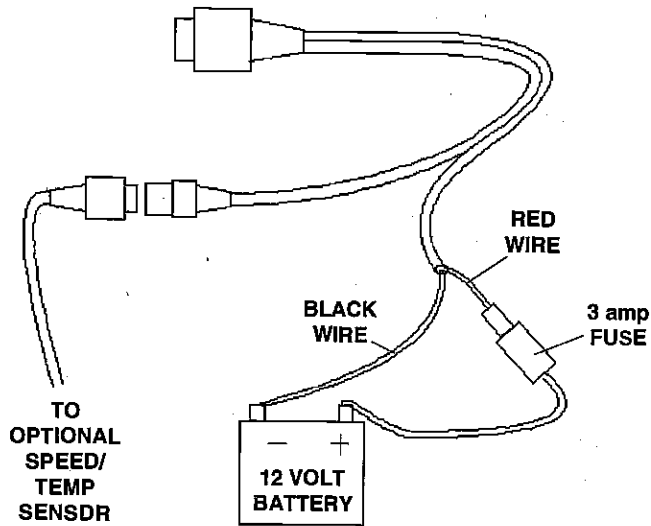

X-70A POWER CONNECTIONS

Notes:

LOWRANCE ELECTRONICS FULL ONE-YEAR WARRANTY

"We", "our", or "us" refers to LOWRANCE ELECTRONICS, INC., the manufacturer of this product. "You" or "your" refers to the first person who purchases this product as a consumer item for personal, family, or household use.

We warrant this product against defects or malfunctions in materials and workmanship, and against failure to conform to this product's written specifications, all for one year (1) from the date of original purchase by you. **WE MAKE NO OTHER EXPRESS WARRANTY OR REPRESENTATION OF ANY KIND WHATSOEVER CONCERNING THIS PRODUCT.** Your remedies under this warranty will be available so long as you can show in a reasonable manner that any defect or malfunction in materials or workmanship, or any non-conformity with the product's written specifications, occurred within one year from the date of your original purchase, which must be substantiated by a dated sales receipt or sales slip. Any such defect, malfunction, or non-conformity which occurs within one year from your original purchase date will either be repaired without charge or be replaced with a new product identical or reasonably equivalent to this product, at our option, within a reasonable time after our receipt of the product. If such defect, malfunction, or non-conformity remains after a reasonable number of attempts to repair by us, you may elect to obtain without charge a replacement of the product or a refund for the product. **THIS REPAIR, REPLACEMENT, OR REFUND (AS JUST DESCRIBED) IS THE EXCLUSIVE REMEDY AVAILABLE TO YOU AGAINST US FOR ANY DEFECT, MALFUNCTION, OR NON-CONFORMITY CONCERNING THE PRODUCT OR FOR ANY LOSS OR DAMAGE RESULTING FROM ANY OTHER CAUSE WHATSOEVER. WE WILL NOT UNDER ANY CIRCUMSTANCES BE LIABLE TO ANYONE FOR ANY SPECIAL, CONSEQUENTIAL, INCIDENTAL, OR OTHER INDIRECT DAMAGE OF ANY KIND.**

Some states do not allow the exclusion or limitation of incidental or consequential damages, so the above limitations or exclusions may not apply to you.

This warranty does NOT apply in the following circumstances: (1) when the product has been serviced or repaired by anyone other than us, (2) when the product has been connected, installed, combined, altered, adjusted, or handled in a manner other than according to the instructions furnished with the product, (3) when any serial number has been effaced, altered, or removed, or (4) when any defect, problem, loss, or damage has resulted from any accident, misuse, negligence, or carelessness, or from any failure to provide reasonable and necessary maintenance in accordance with the instructions of the owner's manual for the product.

We reserve the right to make changes or improvements in our products from time to time without incurring the obligation to install such improvements or changes on equipment or items previously manufactured.

This warranty gives you specific legal rights and you may also have other rights which may vary from state to state.

REMINDER: You must retain the sales slip or sales receipt proving the date of your original purchase in case warranty service is ever required.

LOWRANCE ELECTRONICS

12000 E. SKELLY DRIVE TULSA, OK 74128

(800) 324-1358

TRANSDUCER

Some X-70A's are sold with a HS-WS transom mount transducer. It can be installed on any outboard or stern-drive (inboard\outboard) powered boat. It can also be permanently installed inside the boat to "shoot-through" the hull on some fiberglass boats.

The "kick-up" mounting bracket helps prevent damage if the transducer strikes an object while the boat is moving. If the transducer does "kick-up", the bracket can easily be pushed back in place without tools.

If your unit came with a transducer, read this section carefully before attempting the installation. Determine which of the mounting positions is right for your boat. Use extreme care if mounting the transducer inside the hull, since once it is epoxied into position, the transducer usually cannot be removed. Remember, the transducer location is the most critical part of a sonar installation. If it isn't done properly, the sonar can't perform at it's designed potential.

Location - General

1. The transducer must be placed in a location that has a smooth flow of water at all times. If the transducer is to be mounted inside the hull, then the chosen location must be in the water at all times. If the transducer is not placed in a smooth flow of water, interference will show on the sonar's display in the form of random lines or dots whenever the boat is moving.
2. The transducer should be installed with it's face pointing straight down, if possible.
3. If the transducer is mounted on the transom, make certain it doesn't interfere with the trailer or hauling of the boat. Also, don't mount it closer than approximately one foot from the engine's lower unit. This will prevent cavitation interference with the propeller. Typically, the transducer should be mounted as deep in the water as possible. This increases the chance that it will be in the water in high speed and reduces the possibility of air bubble interference.
4. If possible, route the transducer cable away from other wiring on the boat. Electrical noise from engine wiring, bilge pumps, and areators can be displayed on the sonar's screen. Use caution when routing the transducer cable around these wires.

Shoot-thru-hull v.s. Transom Mounting

Typically, shoot-thru-hull installations give excellent high speed operation and good to excellent depth capability. There is no possibility of damage from floating objects. It can't be knocked off when docking or loading on the trailer.

However, the shoot-thru-hull installation does have its drawbacks. One, some loss of sensitivity does occur, even on the best hulls. This varies from hull to hull, even from different installations on the same hull. This is caused by differences in hull layup and construction. Two, the angle of the transducer cannot be adjusted for the best fish arches. This can be a problem on some hulls that sit with the bow high when at rest or at slow trolling speeds. Follow the procedure listed in the shoot-thru-hull installation section in this manual to determine if you can satisfactorily shoot through the hull.

TRANSOM MOUNT - Assembly

1. First attach the mounting bracket's halves together as shown below. Next, slide the rubber pad into the space between the two slots. This pad keeps tension on the bracket's latch, preventing it from opening at a low speed. Don't close the bracket at this time!

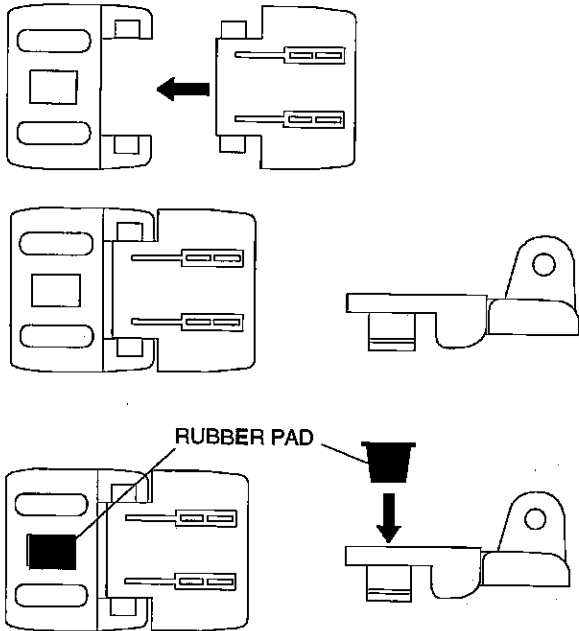

5

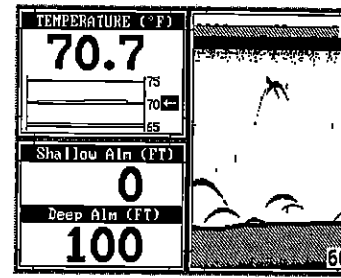

GROUP "D"

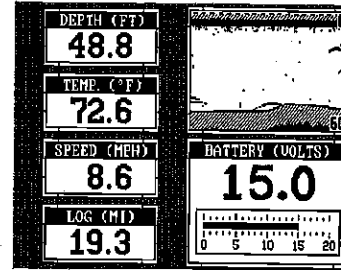

GROUP "F"

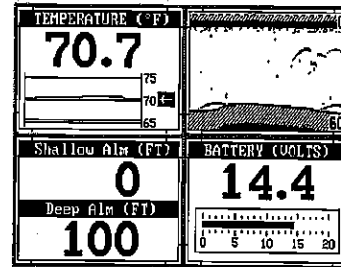

GROUP "H"

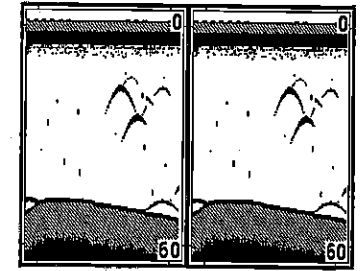

GROUP "E"

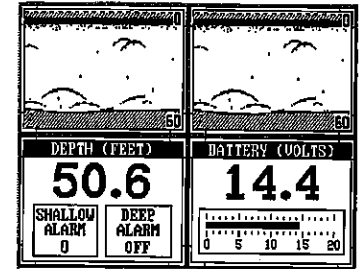

GROUP "G"

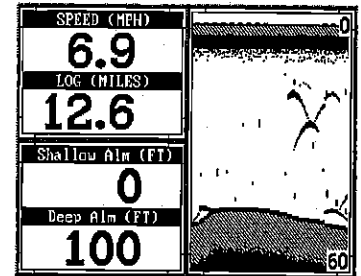

GROUP "I"

42

display, the problem could be one of three things; spark plugs, alternator, or tachometer wiring. Try using resistor spark plugs, alternator filters, or routing the sonar unit's power cable away from engine wiring. Again, routing the power cable directly to the battery helps eliminate noise problems. Make certain to use the in-line fuse supplied with the unit when wiring the power cable to the battery.

When no noise appears on the sonar unit after all of the above tests, then the noise source is probably cavitation. Many novices or persons with limited experience make hasty sonar installations which function perfectly in shallow water, or when the boat is at rest. In nearly all cases, the cause of the malfunction will be the location and/or angle of the transducer. The face of the transducer must be placed in a location that has a smooth flow of water at all boat speeds. Read your transducer owner's manual for the best mounting position.

WINDOWS SUMMARY

All of the window groups used by the X-70A are shown on the following pages. To view these groups, simply press the WINDOWS key, then repeatedly press the down arrow key. This will "cycle" the unit through all groups. Remember, each group can be customized, however the group will revert to the ones shown on these pages when the unit is turned off.

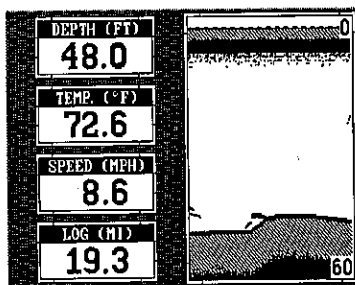

GROUP "A"

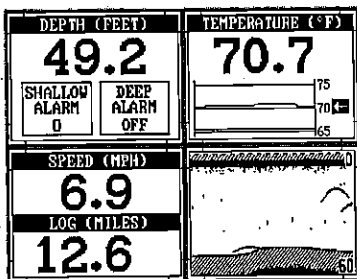

GROUP "B"

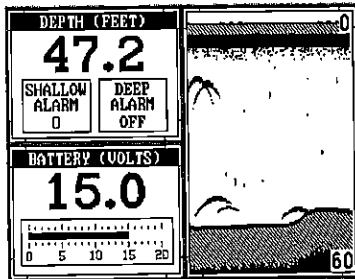

GROUP "C"

2. Slip the transducer's mounting pad between the bracket's mounting "ears". Sandwich two internal lock washers between the transducer and one side of the mounting bracket as shown below. Place one washer on the other side of the transducer.

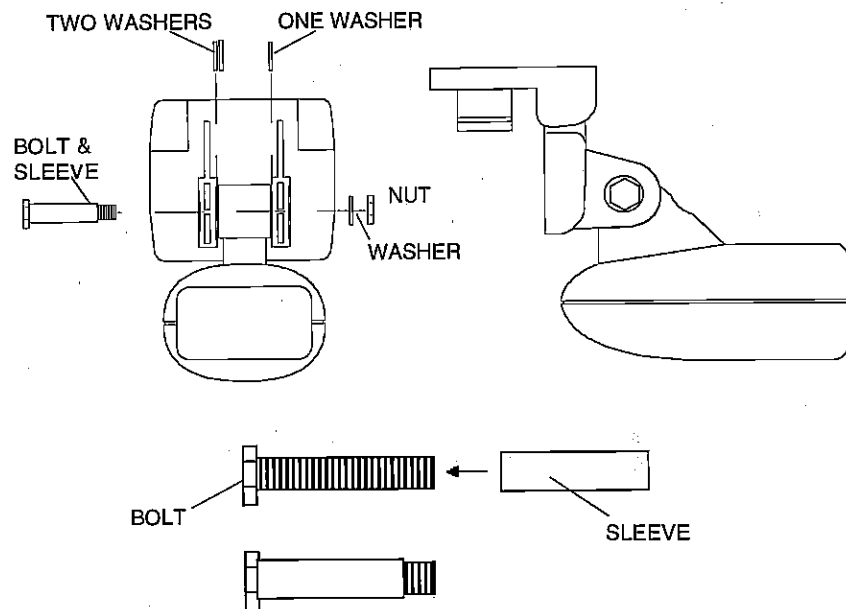

3. Slide the metal sleeve over the bolt. Slip the bolt and sleeve through the bracket, washers, and transducer assembly. Place an internal tooth lock washer over the end of the bolt and thread the nut onto it. Do not tighten the nut at this time. The transducer is now ready for installation.

INSTALLATION - Transom Mount

1. The transducer must be placed in a location that has a smooth flow of water at all times. Air bubbles created by the movement of the boat hull against the water interfere with the sonar signal. This causes "noise" or random marks to appear on the sonar's display. You may need to carefully view the water's path at the transom while the boat is moving to determine the best location for the transducer.

2. Make certain the chosen location doesn't interfere with the boat's trailer. Mount the transducer at least one foot from the engine's lower unit. This will prevent air bubbles from the transducer interfering with the propeller.

CAUTION!
CLAMP THE TRANSDUCER CABLE TO
TRANSOM NEAR THE TRANSDUCER. THIS
WILL HELP PREVENT THE TRANSDUCER
FROM ENTERING THE BOAT IF IT IS
KNOCKED OFF AT HIGH SPEED.

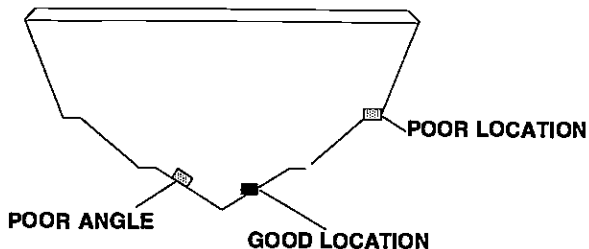
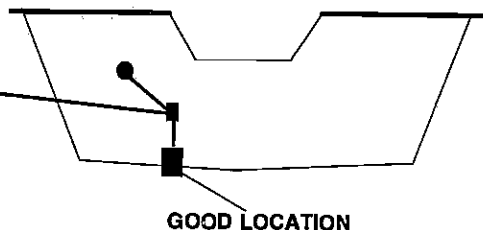

3. Don't mount the transducer directly behind strakes or ribs on the bottom of the hull. Typically, a good location on aluminum boats is between the ribs closest to the engine. (See above.) The port (left) side of the transom is preferred for mounting the transducer, however if this is not possible, the starboard (right) side can be used with good results.

4. Once you determine the best location for the transducer, hold the bracket against the transom. The transducer should be roughly parallel to the ground. The bottom of the hull should be about halfway between the centerline of the transducer and its bottom. (See the illustration below.) Swing the bracket up and mark the transom through the slots in the transducer bracket. Now drill two holes in the center of the slots. Use the #10 stainless steel sheet metal screws supplied with the transducer to loosely attach the bracket to the transom.

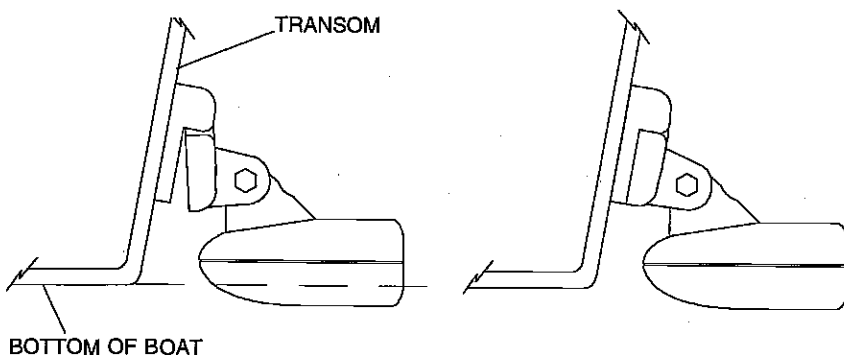

2. The sensitivity may not be high enough. In order for the unit to display a fish arch, it has to be able to receive the fish's echo from the time it enters the cone until it leaves. If the sensitivity is not high enough, the unit displays the fish only when it is in the center of the cone.

3. Use the Zoom feature. It is much easier to display fish arches when zoomed in on a small range of water than a large one. For example, you will have much better luck seeing fish arches with a 30 to 60 foot range than a 0 to 60 foot range. This enlarges the targets, allowing the display to show much more detail.

4. The boat must be moving at a slow trolling speed to see fish arches. If the boat is motionless, fish stay in the cone, showing on the display as straight horizontal lines.

NOISE

A major cause of sonar problems is electrical noise. This usually appears on the sonar's display as random patterns of dots or lines. In severe cases, it can completely cover the screen with black dots, or cause the unit operate erratically, or not at all.

To eliminate or minimize the effects of electrical noise, first try to determine the cause. With the boat at rest in the water, the first thing you should do is turn all electrical equipment on the boat off. Make certain the engine is off, also. Turn your X-70A on, then turn off ASP (Advanced Signal Processing). There should be a steady bottom signal on the display. Now turn on each piece of electrical equipment on the boat and view the effect on the sonar's display. For example, turn on the bilge pump and view the sonar display for noise. If no noise is present, turn the pump off, then turn on the VHF radio and transmit. Keep doing this until all electrical equipment has been turned on, their effect on the sonar display noted, then turned off.

If you find noise interference from an electrical instrument, trolling motor, pump, or radio, try to isolate the problem. You can usually re-route the sonar unit's power cable and transducer cable away from the wiring that is causing the interference. VHF radio antenna cables radiate noise when transmitting, so be certain to keep the sonar's wires away from it. You may need to route the sonar unit's power cable directly to the battery to isolate it from other wiring on the boat.

If no noise displays on the sonar unit from electrical equipment, then make certain everything except the sonar unit is turned off, then start the engine. Increase the RPM with the gearshift in neutral. If noise appears on the

Weak bottom echo, digital readings erratic, or no fish signals:

1. Make certain transducer is pointing straight down. Clean the face of the transducer. Oil, dirt, and fuel can cause a film to form on the transducer, reducing its effectiveness. If the transducer is mounted inside the hull, be sure it is shooting through only one layer of fiberglass and that it is securely bonded to the hull. Do NOT use RTV silicone rubber adhesive or Marinetex™.
2. Electrical noise from the boat's motor can interfere with the sonar. This causes the sonar to automatically increase its Discrimination or noise rejection feature. This can cause the unit to eliminate weaker signals such as fish or even structure from the display.
3. The water may be deeper than the sonar's ability to find the bottom. If the sonar can't find the bottom signal while it's in the automatic mode, the digital will flash continuously. It may change the range to limits far greater than the water you are in. If this happens, place the unit in the manual mode, then change the range to a realistic one, (for example, 0-100 feet) and increase the sensitivity. As you move into shallower water, a bottom signal should appear.
4. Check the battery voltage. If the voltage drops, the unit's transmitter power also drops, reducing its ability to find the bottom or targets.

Bottom echo disappears at high speeds or erratic digital reading or weak bottom echo while boat is moving:

1. The transducer may be in turbulent water. It must be mounted in a smooth flow of water in order for the sonar to work at all boat speeds. Air bubbles in the water disrupt the sonar signals, interfering with its ability to find the bottom or other targets. The technical term for this is Cavitation.
2. Electrical noise from the boat's motor can interfere with the sonar. This causes the sonar to automatically increase its Discrimination or noise rejection feature. This can cause the unit to eliminate weaker signals such as fish or even structure from the display. Try using resistor spark plugs or routing the sonar unit's power and transducer cables away from other electrical wiring on the boat.

No fish arches when the Fish ID feature is off:

1. Make certain transducer is pointing straight down. This is the most common problem if a partial arch is displayed. See the Fish Arch section in your owner's manual for more information.

5. Adjust the transducer and bracket so that the front of the transducer is slightly lower than the back. See the section on fish arches in this manual for proper transducer angles. Tighten all screws. (CAUTION: Don't overtighten the bolt that holds the transducer to the bracket. Overtightening the bolt may result in a distorted bracket which will allow the transducer to "kick-up" at high speed.) Snap the transducer bracket together by pressing the outer bracket (the one with the transducer attached) against the one screwed to the transom.

IMPORTANT!

Clamp the transducer cable to the transom close to the transducer. This will prevent the transducer from entering the boat if it is knocked off at high speed.

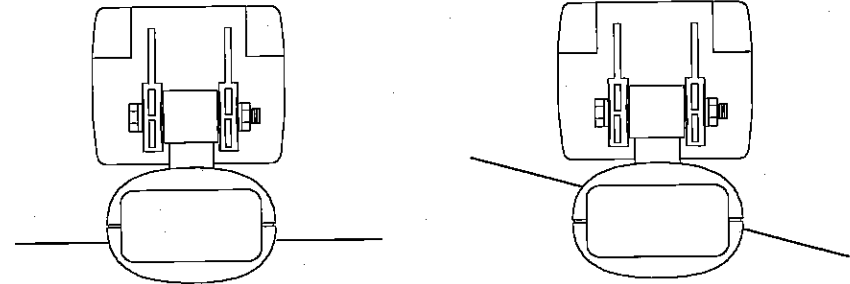

FLAT-BOTTOM HULL

DEEP-VEE HULL

NOTE: Some aluminum boats with strakes or ribs on the outside of the hull create large amounts of turbulence at high speed. These boats typically have large outboard motors capable of propelling the boat at speeds over 35 mph. The transducer should be mounted as far below the hull as possible on these boats. (See below) This will place the face of the transducer below the turbulent water, allowing the sonar unit to work at high speeds.

6. Route the transducer cable to the sonar unit. Keep the transducer cable away from other wiring on the boat, if possible. Electrical noise from engine wiring or bilge pumps can be picked up on the transducer cable. This can show up as unwanted interference on the sonar display.

7. Make a test run to determine the results. If there is interference on the display when running the boat at high speed, try lowering the transducer's bracket as shown at right.

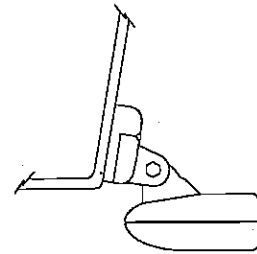

SHOOT-THRU-HULL INSTALLATION

The transducer installation inside a fiberglass hull must be in an area that does not have air bubbles in the resin or separated fiberglass layers. The sonar signal must pass through solid fiberglass. A successful transducer installation can be made on hulls with flotation materials (such as plywood, balsa wood, or foam) between layers of fiberglass if the material is removed from the chosen area. For example, some manufacturers use a layer of fiberglass, then a core of balsa wood, finishing with an outer layer of fiberglass. Removing the inner layer of fiberglass and the balsa wood core exposes the outer layer of fiberglass. The transducer can then be epoxied directly to the outer layer of fiberglass. After the epoxy cures, the hull is watertight and structurally sound. Remember, the sonar signal must pass through solid fiberglass. Any air bubbles in the fiberglass or the epoxy will reduce or eliminate the sonar signals.

To choose the proper location for thru-hull mounting, anchor the boat in 60 feet of water. Add a little water to the sump of the boat. Plug the transducer into the sonar unit, turn it on, then hold the transducer over

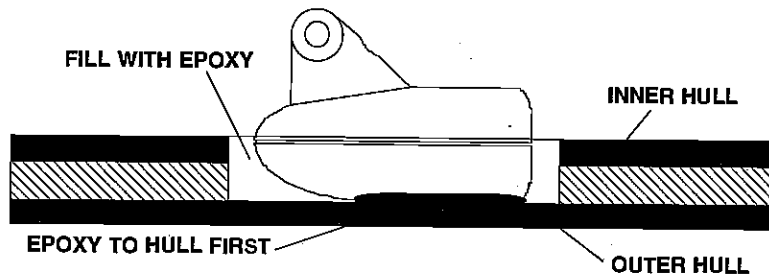

the side of the boat. Adjust the sensitivity and range controls until a second bottom echo is seen on the display. (you will need to turn the automatic and ASP features off.) Don't touch the controls once they've been set. Next, take the transducer out of the water and place it in the water in the sump of the boat. Observe the sonar signal to see if there is a noticeable decrease in sensitivity. The second bottom signal may disappear and the bottom signal may decrease in intensity. Move the transducer around to find the best location. If the sensitivity control has to be increased greatly to compensate, then the transducer should be mounted on the outside of the hull. If not, then mark the location that shot through the hull the best and follow the instructions on the next pages for a shoot-thru-hull mounting.

etc., the sensitivity sometimes cannot be increased enough to get fish arches.

One of the best ways to get fish arches is to expand or "zoom" a segment of the water. For example, using the 2X or 4X zoom feature. The smaller the segment, the better the screen resolution will be. The zoom feature expands the echoes, making it easier to see detail. For the best results, turn the sensitivity up as high as possible without getting too much noise on the screen. In medium to deep water, this method should work to display fish arches.

If you see fish signals when the unit is in the manual mode, but don't get fish symbols when the Fish I.D. feature is on, try increasing the sensitivity.

TROUBLESHOOTING

If your unit is not working, or if you need technical help, please use the following troubleshooting section before contacting the factory customer service department. It may save you the trouble of returning your unit.

Unit won't turn on:

1. Check the power cable's connection at the unit. Also check the wiring.
2. Make certain the power cable is wired properly. The red wire connects to the positive battery terminal, black to negative or ground.
3. Check the fuse.
4. Measure the battery voltage at the unit's power connector. It should be at least 11 volts. If it isn't, the wiring to the unit is defective, the battery terminals or wiring on the terminals are corroded, or the battery needs charging.

Unit freezes, locks up, or operates erratically:

1. Electrical noise from the boat's motor, trolling motor, or an accessory may be interfering with the sonar unit. Re-routing the power and transducer cables away from other electrical wiring on the boat may help. Route the sonar unit's power cable directly to the battery instead of through a fuse block or ignition switch.
2. Inspect the transducer cable for breaks, cuts, or pinched wires.
3. Check both the transducer and power connectors. Make certain both are securely plugged in to the unit.

edge of the signal shows you the true depth. The rest of the signal tells you whether you are over rocks, mud, etc.

if the cone passes over a fish in shallow water, the signal displayed on the X-70A may not arch at all. This is due to the narrow cone diameter and the resolution limitations of the display.

FISH ARCHES

Fish arches are created when the cone of sound passes over a fish. The distance to a fish when the cone first strikes it is shown as "A" on the next page. When the center of the cone strikes the fish, the distance is shorter as shown "B". As the cone leaves the fish, the distance increases again as shown in "C".

Very small fish probably will not arch at all. Medium sized fish will show a partial arch, or a shape similar to an arch if they're in deep water. Large fish will arch, but turn the sensitivity up in deeper water to see the arch. Because of water conditions, such as heavy surface clutter, thermoclines,

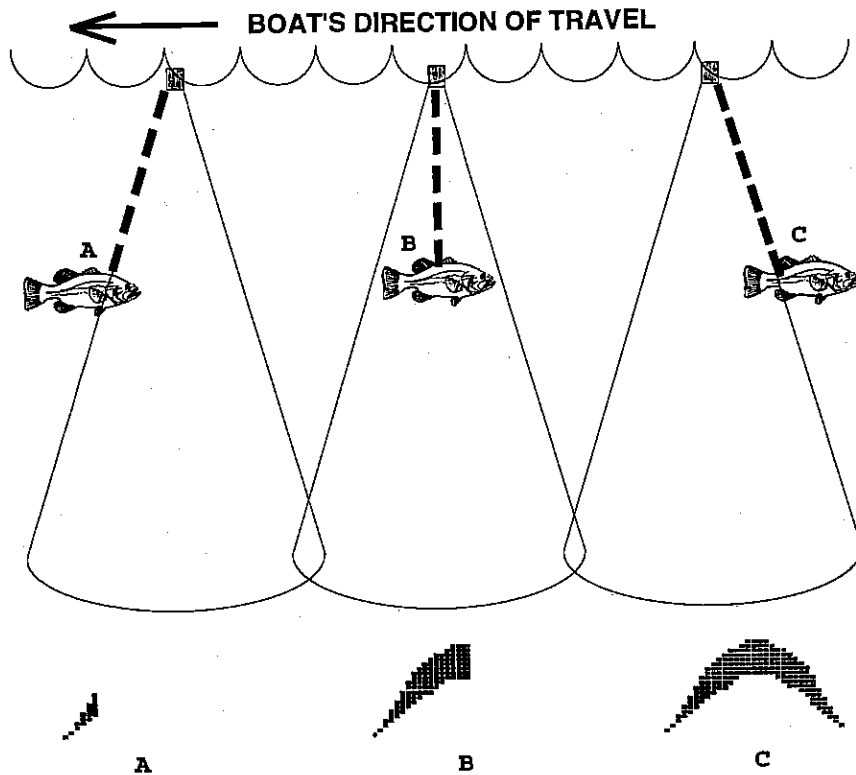

37

TRANSDUCER LOCATION
(HIGH SPEED)

TRANSDUCER LOCATION
(TROLLING SPEED)

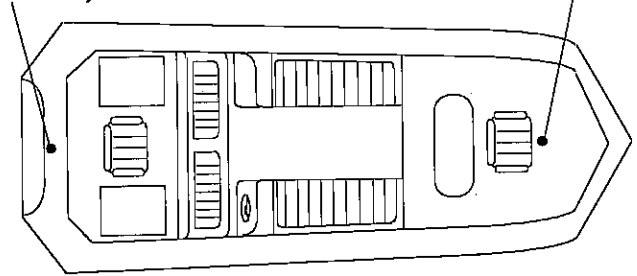

Shoot-thru-hull Installation

1. Make certain the area is clean, dry, and free of oil or grease, then sand both the inside surface of the hull and the face of the transducer with 100 grit sandpaper. The surface of the hull must be flat so the entire transducer face is in contact with the hull prior to bonding.

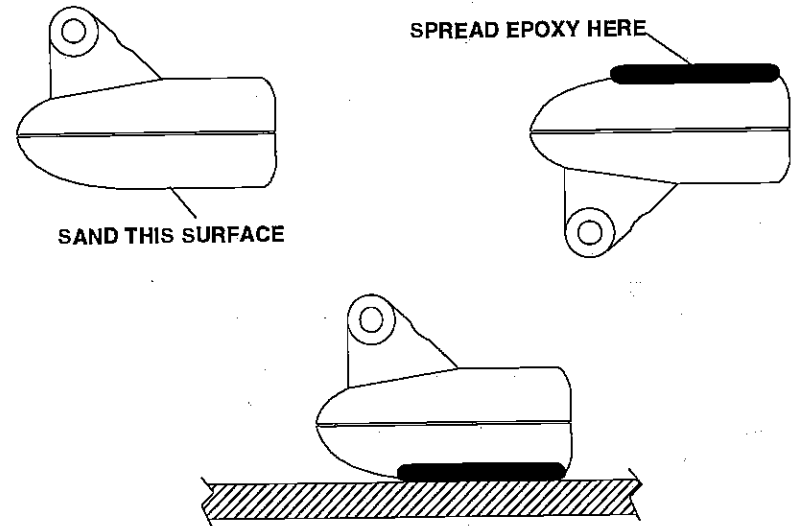

2. Follow the instructions on the epoxy package and mix it thoroughly. Do not mix it too fast, as it will cause bubbles to form in the epoxy. (NOTE! Use only the epoxies specified on page 1 of this manual! Failure to use one of these epoxies may result in poor sonar performance!) Apply a small amount on the face of the transducer as shown above, then spread a small amount onto the sanded area on the hull. Place the transducer into the epoxy, twisting and turning it to force any air bubbles out from under the transducer face. The face of the transducer should be parallel with the hull, with a minimum amount of epoxy between the hull and transducer. After the epoxy dries, route the cable to the X-70A.

10

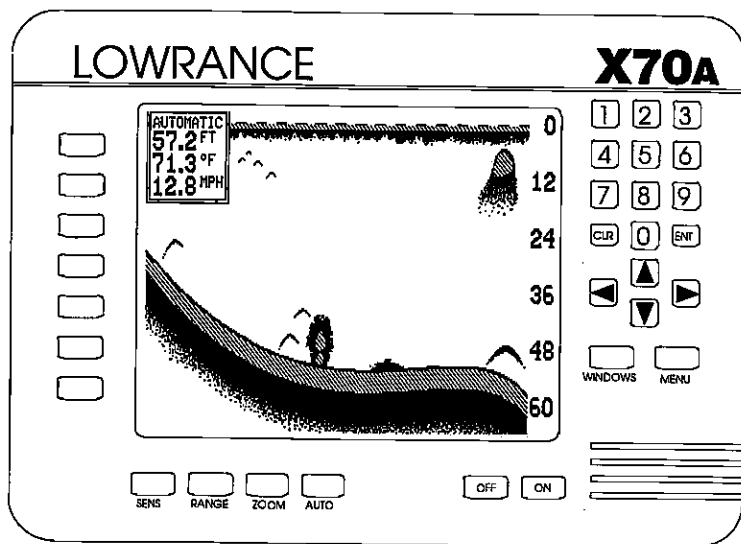

KEYBOARD

The keyboard has keys arranged in a vertical column on the left plus a horizontal row at the bottom. A ten-key pad and arrow keys on the right side of the screen lets you enter and change data on the screen. The keys in the left column are used for menu selections. The menu key in the bottom right corner of the keyboard activates the first menu page. The keys along the bottom of the screen are used to activate the sensitivity menu, adjust the range, zoom, and switch from automatic to the manual mode.

WINDOWS - This key gives you access to the windows mode, which lets you customize displays.

MENU - Press this key to show the menus and gain access to most functions.

SENS - Press this key to adjust the unit's sensitivity.

RANGE - This key lets you adjust the range when the unit is in the manual mode.

ZOOM - The X-70A gives you 2X and 4X zoom capability with this key.

TRANSDUCER CONE ANGLES

The sound waves from the transducer spread out into the water in a cone shaped beam. This looks much like the beam from a flashlight. The angle between the outside edges of the cone is the cone angle.

Lowrance offers a choice of transducers with either an 8 or 20 degree cone angle. The transducer supplied with the X-70A has a 20 degree cone angle. Typically, wide cone angle transducers (20 degrees) are ideal for operating in shallow to medium water depths. The 20 degree cone angle allows you to see more of the underwater world. In 15 feet of water the 20 degree cone covers an area about six feet across. The 8 degree transducer covers only about a two foot circle.

The 20 degree transducer is almost always the best to use in fresh water, the 8 degree mostly in salt water. In a deep water environment, (300 feet - fresh water, 100 feet - salt water) the narrow cone angle is more desirable. Since the sound energy is concentrated in a smaller area, it can penetrate to much deeper depths.

Both 8 degree and 20 degree transducers give accurate bottom readings, even though the bottom signal is much wider on the 20 degree model. This is because you are seeing more of the bottom. Remember, the shallow

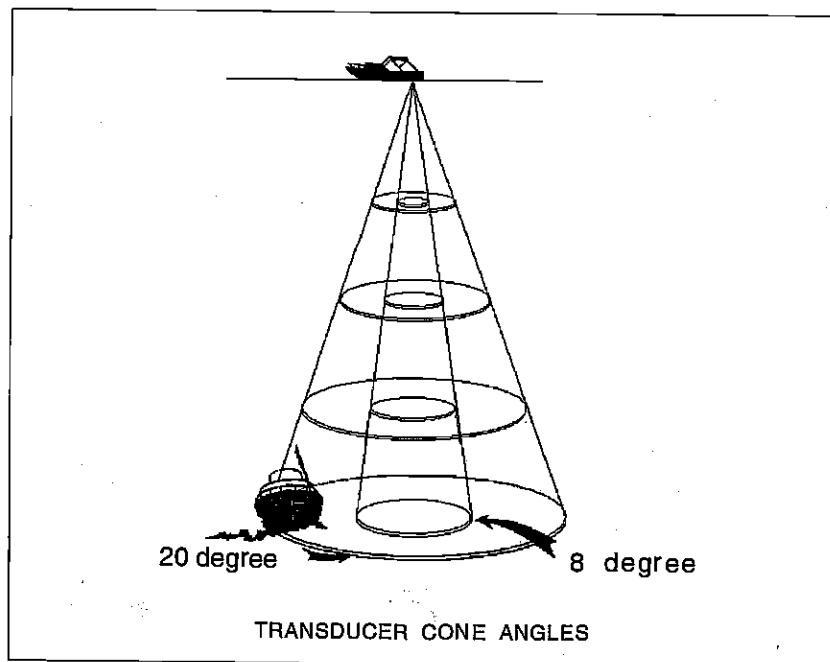

sources such as bilge pumps, engine ignition systems and wiring, air bubbles passing over the face of the transducer, even vibration from the engine. In all cases, noise can produce unwanted marks on the display.

The ASP feature has three levels - Low, Medium, and High. If you have high noise levels, try using the "High" ASP setting. However, if you are having trouble with noise, we suggest that you take steps to find the interference source and fix it, rather than continually using the unit with the high ASP setting.

However, there are times when you may want to turn the ASP feature off. This allows you to view all incoming echoes before they are processed by the ASP feature.

To change the ASP level, press the MENU key, then press the key next to the "More" label until the fifth menu page appears. Then press the key next to the "Level of ASP" label until the desired level is obtained.

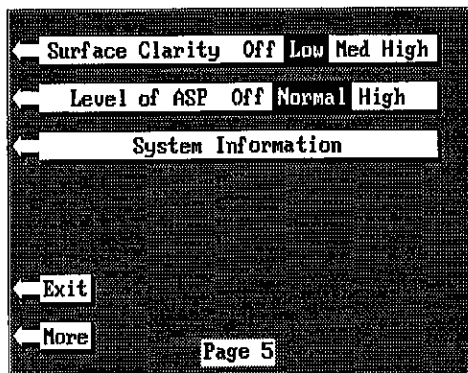

SYSTEM INFORMATION

The System Information menu gives you the date and revision number of the software used in the X-70A. To view this menu, press the Menu key, then press the key next to the "More" label until the fifth menu page appears. Now press the key next to the "System Information" label. A screen similar to the one at right appears. To return to the sonar screen, press the key next to the "Exit" label.

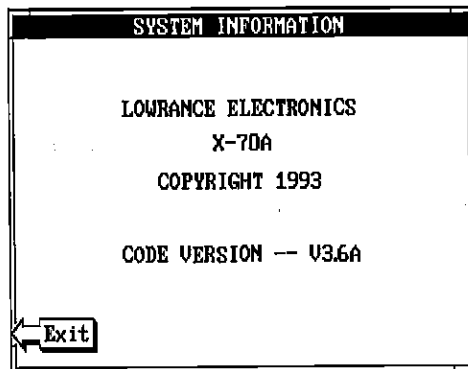

AUTO - This turns the automatic feature off and on.

CLR - This key clears menus and erases entries from the screen.

ENT - This key is used to enter numbers and make selections.

ARROW KEYS - These keys are used to make menu selections and to move objects on the screen.

ON - The ON key turns the X-70A on.

OFF - Press and HOLD the Off key to turn the X-70A off.

DISPLAY - General

The lights are turned on for approximately ten seconds when the X-70A is first turned on. Menus appear at the same time. To keep the lights on, press the key adjacent to the Light label. It controls the backlighting used on the display and keyboard. If you don't want the lights on, wait ten seconds and the lights will automatically turn themselves off. The menu will also disappear after ten seconds, or you can turn them off by pressing the CLR key on the left side of the zero (0) key.

The Metric label at the top of the screen works the same way. Press the key adjacent to the Metric label to change the depth from feet to meters. This also changes the temperature display to degrees Celsius, speed to knots, and log to kilometers.

The Display menu on the right side of the screen let you adjust the display's contrast for the best viewing angle. Pressing the left arrow key decreases the contrast, the right arrow increases it. After setting the contrast for the best viewing angle, press the CLR key to erase the menu or wait approximately ten seconds and it will automatically erase. See the Display Contrast section for more information on this feature.

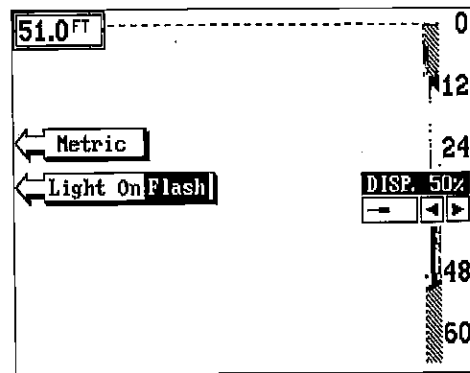

When the X-70A is first turned on, the display will appear similar to the one at left. The word "AUTOMATIC" in the upper left corner of the display indicates the automatic feature is on. The digital bottom depth is also displayed in this box.

MENUS

The X-70A uses menus extensively to guide you through the functions and features of the unit. The menu key accesses many of these features, allowing you to customize the unit to your particular needs and water conditions. Although you may have to leave one menu and enter another to reach the desired function, all you have to do is press the key next to the "More" label to select the next menu. To return to the sonar screen, simply press the key next to the "Exit" label or press the CLR key.

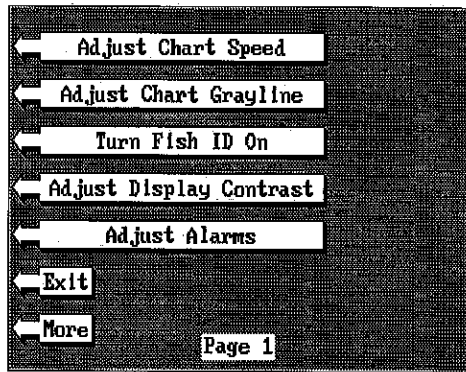

HELP

An extremely useful feature incorporated into the X-70A series is the Help menus. Virtually every feature has a help menu label that, when pressed, gives one or more pages of text describing how to use that feature. For example, pressing the AUTO key brings up a menu letting you switch the unit into or out of the automatic mode. A help label also appears on the screen. Pressing the key adjacent to the help label gives you a description of how automatic works and how it affects different functions.

WINDOWS

You can change the displays on the X-70A by using the windows feature. This lets you customize displays to your own fishing or boating situations. This feature gives you 9 different window screens.

The screens available in the windows mode are divided into two or more windows per screen. Each screen of windows is called a "group". Group "A" as shown at right has the digital displays in one window and the sonar chart in the other.

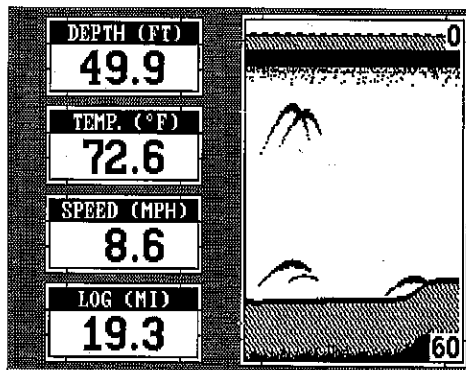

13

MENU - PAGE 5

ADJUST CHART SURFACE CLARITY

The markings extending downward from the zero line on the chart are called "surface clutter." These markings are caused by wave action, boat wakes, temperature inversion, and other natural causes.

The Surface Clarity Control (SCC) reduces or eliminates surface clutter signals from the display. SCC varies the sensitivity of the receiver, decreasing it near the surface and gradually increasing it as the depth increases. The maximum depth that SCC will affect is 75% of the selected depth range. For example, on a 0-60 foot range with maximum SCC, surface clutter will be reduced down to 45 feet.

There are three levels of SCC available on the X-70A: low, medium, and high. When it's turned on for the first time, the SCC level is low. To change it, press the MENU key, then press the key next to the "More" label until the fifth menu page appears. Now press the key adjacent to the "ADJUST CHART SURFACE CLARITY" label until the black box is on the desired SCC level.

Press the key next to the "EXIT" label when you're finished.

ASP (Advanced Signal Processing)

The ASP feature is a noise rejection system built into the X-70A that constantly evaluates the effects of boat speed, water conditions, and interference. This automatic feature gives you the best display possible under most conditions.

The ASP feature is an effective tool in combating noise. In sonar terms, noise is any undesired signal. It is caused by electrical and mechanical

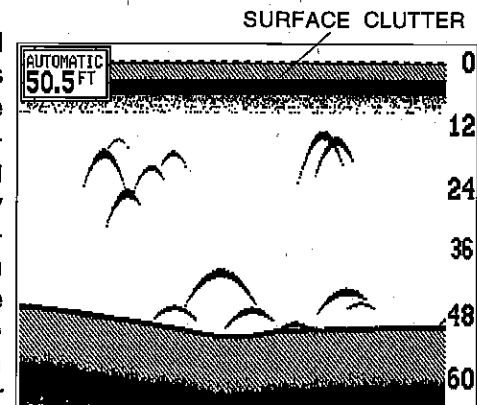
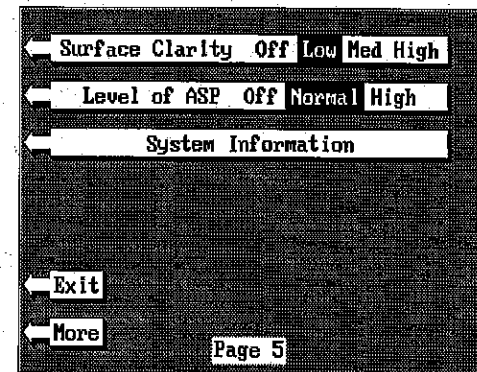

34

SELECT UNITS OF MEASURE

The X-70A can display the water depth in feet, fathoms, or meters, surface water temperature in degrees Fahrenheit or Celsius, speed in statute miles per hour, kilometers per hour, or knots, and distance (log) in miles, kilometers, or nautical miles.

To change the units of measure, press the MENU key, then press the key next to the "More" label until the fourth menu page appears. Now press the key adjacent to the "Select Units of Measure" label. The screen shown below appears. The black box on each line shows the unit of measure currently in use. In the screen shown above, the units of measure are in feet for the depth, temperature in degrees Fahrenheit, speed is in statute miles per hour and log is in statute miles.

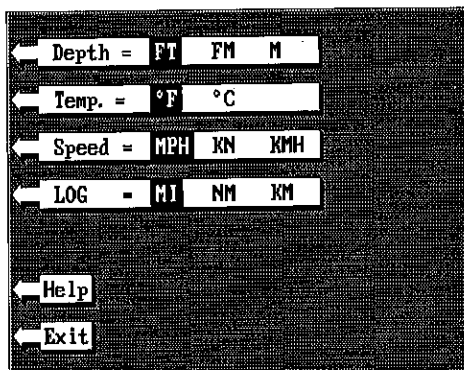

Press the key adjacent to the unit that you wish to change. For example, press the key next to the "Depth" label two times to switch from feet to meters. This moves the black box two times from the "FT" to the "M". When you have the units of measure set as desired, press the key next to the "Exit" label.

CLEAR DISTANCE LOG

The X-70A's log starts counting distance as soon as the X-70A is turned on. To reset the distance log to zero, press the MENU key until the "CLEAR DISTANCE LOG" label appears, then press the key adjacent to that label. The X-70A returns to the sonar screen with the log set to zero.

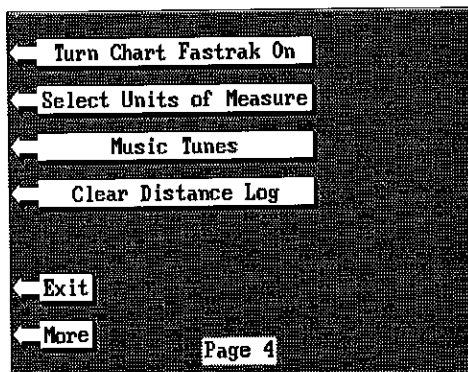

Note: This feature requires an optional speed/temperature sensor.

To use the windows feature, first press the WINDOWS key. A screen similar to the one shown at right appears. The menu on the right side of the screen lets you switch between the "pages" of displays. These are lettered "A" through "I". Group "A" shows first. Press the down arrow key to move forward through the screens.

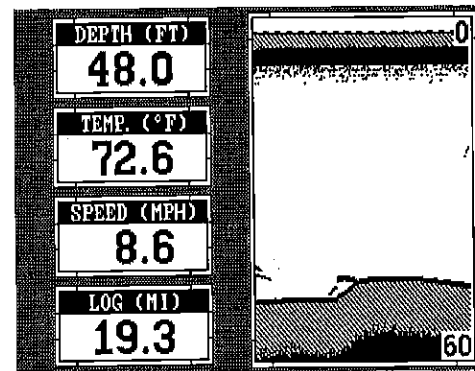

Press the up arrow key to move backward. For example, pressing the down arrow key once shows the group "B" screen. To return to the full sonar screen, press the "FULL CHART" key at the top left corner of the X-70A.

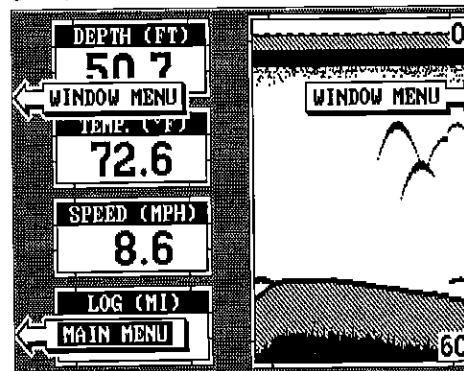

Every one of the group screens can be modified to some extent. For example, press the MENU key while group "A" is displayed. Three new labels appear on the display as shown above. Two of these labels are window menus. Pressing the key adjacent to one of the "window menu" labels gives you a menu with functions that relate only to that window. For example, if you press the key adjacent to the window menu label on the sonar chart window, the screen will clear and you will have a new menu with selections such as "ADJUST CHART SPEED" and "ADJUST GRAYLINE". Other window menus let you change the units of measure or adjust alarms.

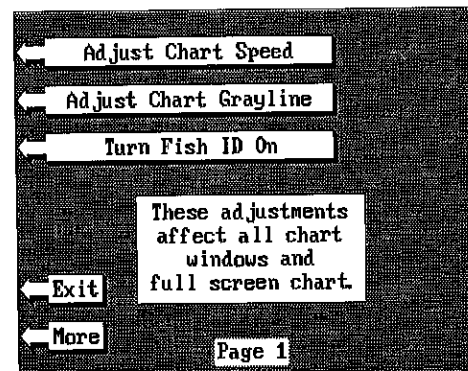

To exit from a window menu, press the CLR key.

VIEWING WINDOWS OPTIONS

To see all of the available window options, press the WINDOWS key, then press the MENU key. Now press the key adjacent to the "MAIN MENU" label. Finally, press the key next to the "VIEW ALL WINDOWS" label. The screen at right appears.

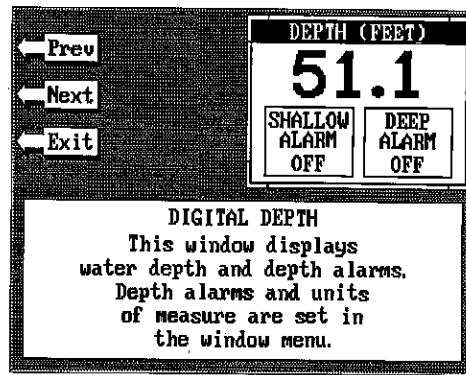

The first window appears in the upper right corner of the screen. A description of the screen shows in the box at the bottom of the screen. Now press the key adjacent to the "NEXT" label. This changes the window and description. When you've finished viewing the windows, press the CLEAR key.

MODIFYING GROUPS

To modify or "customize" a group, first press the WINDOWS key, then press the MENU key. Now press the key adjacent to the "MAIN MENU" label at the bottom of the screen. The screen shown at right appears.

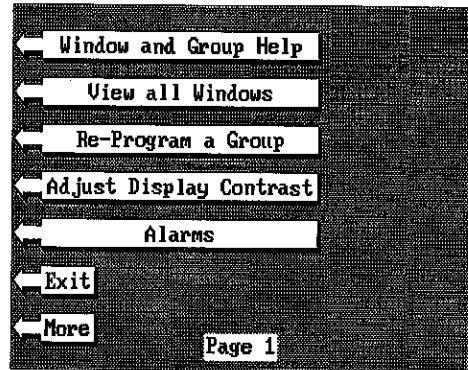

Now press the key adjacent to the "RE-PROGRAM A GROUP" label. The screen shown below appears.

Select the letter of the group you wish to customize by pressing the key adjacent to the group's label. If the label isn't shown on this page, press the key adjacent to the "MORE" label. In this example, the key next to the "GROUP A" label was pressed. The screen shown at the top of the next page appears.

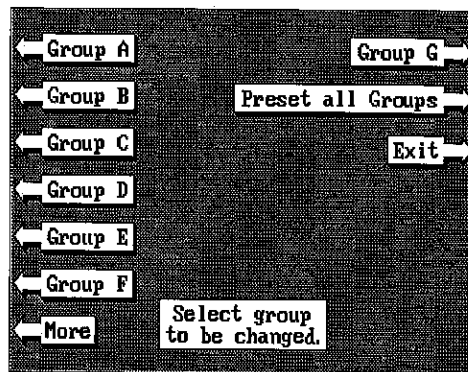

15

is 16.4 feet. To turn the chart cursor on, press the MENU key until the third menu screen appears as shown at the top of this page. Now press the key next to the "Turn Chart Cursor On" label. A screen similar to the one at the top of the next page appears. To move the chart cursor, simply press the up or down arrow keys. This lets you move the cursor to verify a target's depth. To turn the chart cursor off, then press the key next to the "Turn Chart Cursor Off" label on the third menu page. The X-70A returns to the sonar screen with the cursor turned off.

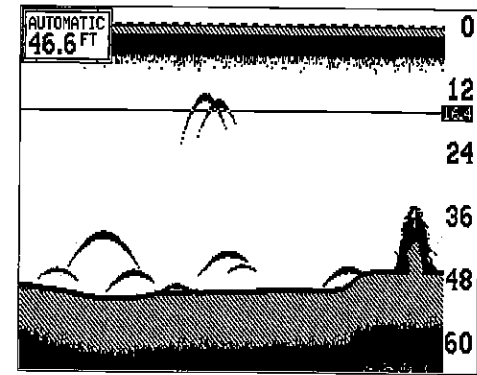

MENU - PAGE 4

FASTRAK

This feature converts all echoes to short horizontal lines on the display's far right side. The graph continues to operate normally. FASTRAK gives you a rapid update of conditions directly under the boat. This makes it useful for ice fishing, or when you're fishing at anchor. Since the unit is not moving, fish signals are long, drawn out lines on a normal chart display. FASTRAK converts the graph to a vertical bar graph that, with practice, makes a useful addition to fishing at a stationary location.

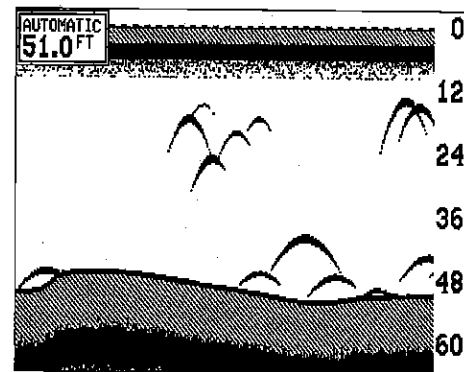
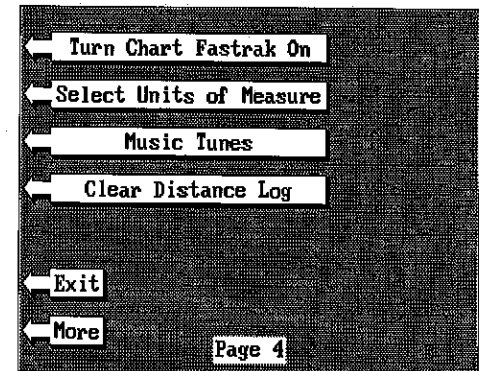

To turn FASTRAK on, press the MENU key, then press the key next to the "More" label until the fourth menu page appears. Now press the key adjacent to the "Turn Chart Fastrak On" label. To turn it off, repeat the same steps. The "TURN FASTRAK OFF" label appears on this page when Fastrak is on.

32

DIGITAL SONAR

When the X-70A is turned on for the first time, the digital depth display is located at the top left corner of the screen. This display comes from a separate digital sonar built into the unit. It displays only the bottom depth. If it loses the bottom, the last known depth will flash on the display. When the digital finds the bottom, it will automatically display the bottom depth again. The digital sonar can be turned off, however this also turns all automatic features off also, such as auto sensitivity, auto ranging, and the Fish I.D. feature.

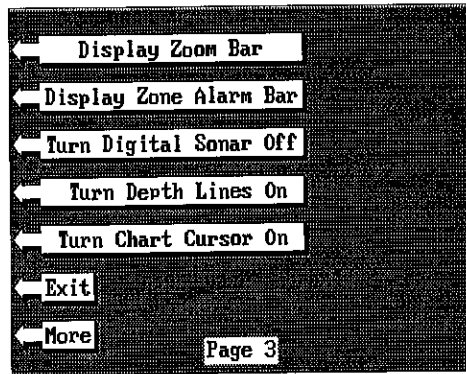

To turn the digital sonar off, press the Menu key, then press the key next to the "More" label until the third menu page appears. Now press the key adjacent to the "Turn Digital Sonar Off" label. To turn it back on again, repeat the same steps.

DEPTH LINES

The X-70A prints depth lines across the display to help you determine the depth of targets. When it's turned on for the first time, depth lines are turned off. To turn them on, press the MENU key, then press the key next to the "More" label until the third menu page appears as shown at the top of this page. Now press the key next to the "Turn Depth Lines On" label. A screen similar to the one at right appears.

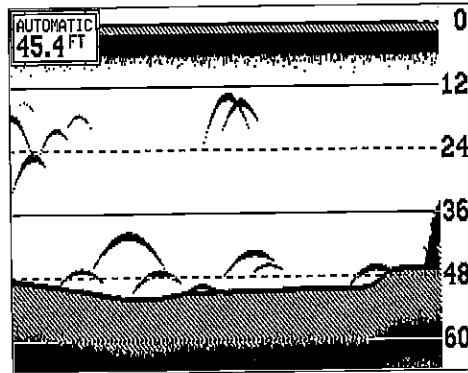

To turn the depth lines off, repeat the above steps, but press the key next to the "Turn Depth Lines Off" label. The X-70A returns to the sonar screen with the depth lines off.

CHART CURSOR

The X-70A has a chart cursor that lets you pinpoint a target's depth. The cursor is simply a movable horizontal line that extends across the display from right to left. A depth box at the far right end of the line shows the line's depth. In the example at the top of the next page, the chart cursor depth

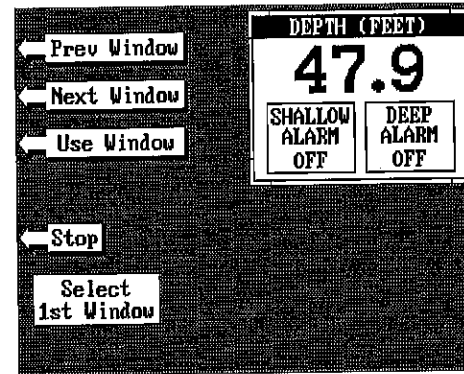

The depth window appears in the upper right corner of the screen. Press the key adjacent to the "NEXT WINDOW" label to move through the windows. If you reach the last window, or if you wish to go backwards through the windows, press the key next to the "PREV WINDOW" label. When the desired window is on the screen, press the key next to the "USE WINDOW" label. The screen clears, placing the new window in the upper left corner of the screen. If the new window takes up half the screen, the unit will place it on the left side of the screen.

Continue with the window selections until the screen is filled. The unit will stay in the windows mode using your new customized screen. If you don't want to fill a screen and only use one, two, or three windows in a group, simply press the key adjacent to the "STOP" label. This saves the group and exits the modify windows mode.

Remember, you can always return to the full screen sonar mode by pressing the "FULL CHART" key in the upper left corner. To switch back to your customized screen from the full screen sonar, simply press the WINDOWS key, then use the down arrow key to switch to the group you customized.

NOTE: Turning the unit off erases all customized screens and user settings!

RESETTING ALL GROUPS

To return all of the groups to their factory settings without turning the unit off and on again, press the WINDOWS key, then press the MENU key, then press the key adjacent to the "MAIN MENU" label. Now press the key adjacent to the "RE-PROGRAM A GROUP" label. Finally, press the key next to the "RESET ALL GROUPS" label.

OPERATION

AUTOMATIC

When the X-70A is first turned on, the Automatic feature is enabled. This is indicated by the word "AUTO" at the top of the screen. The Automatic feature adjusts the sensitivity and range so the bottom signal is displayed in the lower half of the screen at all times.

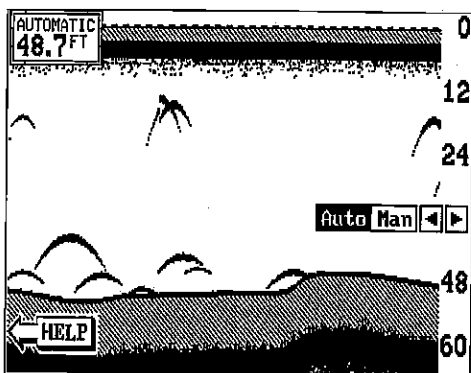
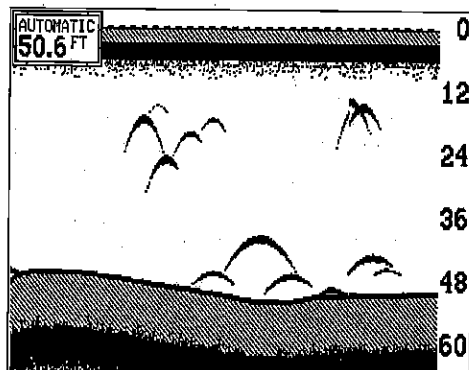

To turn Automatic off, first press the AUTO key. A menu appears at the bottom of the screen above the left and right arrows. Press the left arrow key to switch to the manual mode. The letters "Man" appear in the upper left corner of the display, indicating the unit is in the manual mode. To turn Automatic on, press the AUTO key again, then press the right arrow key.

Remember, when the X-70A is in the automatic mode, you have a limited adjustment range on the Sensitivity control and no control over the Range. Zoom adjusts differently in automatic than manual, also.

MENU - PAGE 3

DISPLAY ZOOM BAR

When the unit is in the zoom mode, the zoom bar doesn't normally show on the screen. The zoom bar shows the section of water on the right side of the screen that the zoom feature displays on the left side. To turn the zoom bar on continuously, first press the MENU key, then press the key next to the "More" label two times. The screen shown above appears. Now press

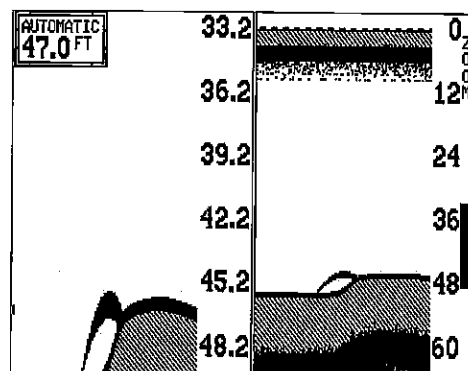
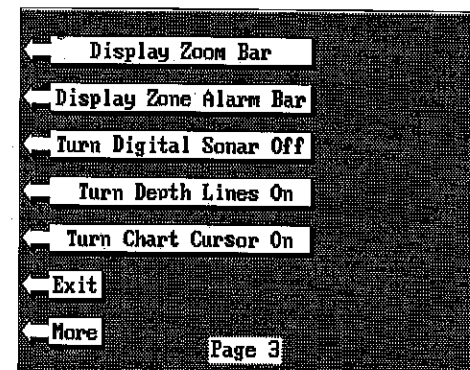

the key next to the "Display Zoom Bar" label. A screen similar to the one at left appears. Note that turning the zoom bar on also turns the zoom feature on.

To turn the zoom bar off, repeat the above steps until the third menu page appears, then press the key adjacent to the "Remove Zoom Bar" label. This removes the zoom bar, but

leaves the unit in the zoom mode. See the zoom section for more information on this feature.

DISPLAY ZONE ALARM BAR

When the zone alarm is on, the zone bar doesn't normally show on the screen. To turn the zone bar on continuously, first press the MENU key, then press the key next to the "More" label until the third menu page appears. Now press the key next to the "Display Zone Alarm Bar" label. The zone alarm bar appears on the right side of the sonar screen. This also turns the zone alarm on.

To turn the zone bar off, repeat the above steps, until the third menu page appears, then press the key adjacent to the "Remove Zone Bar" label. Note that this doesn't turn the zone alarm off. See the Alarms section for more information on the zone alarm.

TURN DIGITAL INSTRUMENT BOX OFF

The digital box is displayed in the upper left corner of the full sonar screen. It has the digital depth and automatic/manual indicators. To turn this box off, press the MENU key then the key next to the "More" label, then the key adjacent to the "TURN DIGITAL INSTRUMENT BOX OFF" label. Repeat the above steps to turn the box on.

CONSTRUCT DIGITAL INSTRUMENT BOX

The X-70A can display the depth, speed, surface water temperature, and distance log in the upper left portion of the screen. When the X-70A is first turned on, only the depth is displayed. You can turn each digital display on as desired or turn all of them off, as desired.

To select the digital displays menu, first press the menu key, then press the key next to the "More" label. Next, press the key adjacent to the "CONSTRUCT DIGITAL INSTRUMENT BOX" menu. A screen appears that is similar to the one below.

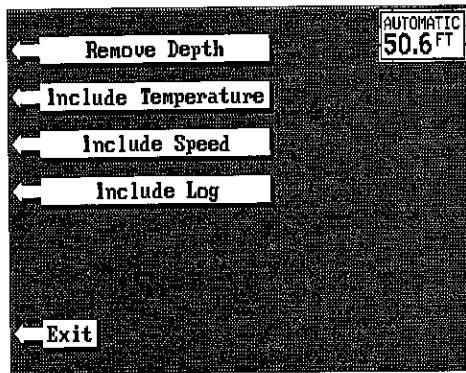

Now press the key adjacent to the desired display. For example, to turn the temperature display on, press the key adjacent to the "Include Temperature." label. Once you do this, the digital display in the corner of the screen will show the temperature in addition to the depth. The temperature menu label now shows "Remove Temperature".

You can turn each display on or off individually.

Press the CLR key to exit from this menu or wait approximately ten seconds and the menus will automatically clear.

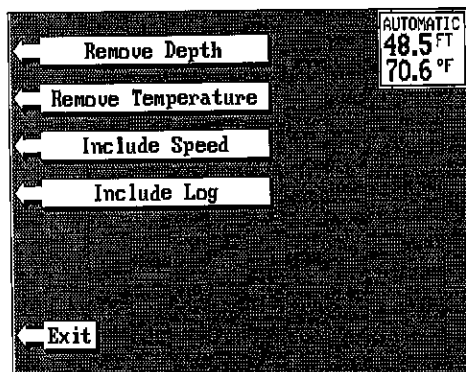

SENSITIVITY

The sensitivity key on the X-70A controls the ability of the unit to pick up echoes. A low sensitivity level excludes much of the bottom information, fish signals, and other target information. High sensitivity levels enables you to see this detail, but it can also clutter the screen with many undesired signals. Typically, the best sensitivity level shows a good solid bottom signal with Grayline and some surface clutter.

When the X-70A is in the Automatic mode, the sensitivity is automatically adjusted to keep a solid bottom signal displayed, plus a little more. This gives it the capability to show fish and other detail.

However, situations occur where it becomes necessary to increase or decrease the sensitivity. This typically happens when you wish to see more detail, so an increase in sensitivity is indicated. The procedure to adjust it is the same whether the unit is in the automatic or manual mode.

To adjust the sensitivity, press the SENS key. The sensitivity adjust menu appears on the right side of the screen.

The sensitivity menu has left and right arrows, plus a horizontal bar graph. The graph gives a visual indication of the sensitivity level. The number above the arrows also shows the percentage of sensitivity in use.

To increase the sensitivity level, press the right arrow key. As you press the key, the menu's bar graph will grow wider and the percentage will increase in value. You can also see the difference on the chart record as it scrolls. When the sensitivity is at the desired level, release the key.

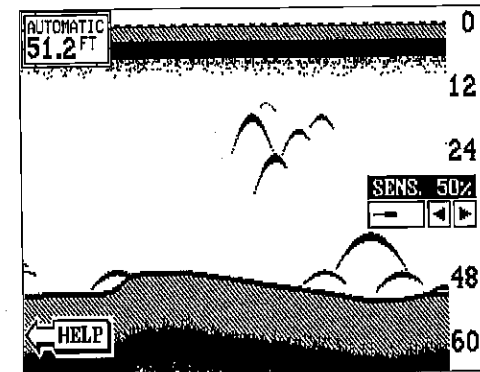

To decrease the sensitivity level, press the key adjacent to the left arrow. The bar graph and percentage will decrease. When the sensitivity is at the desired level, release the key. When you reach either the maximum or minimum limit, a tone sounds.

To turn the menus off, press the CLR key or wait a few seconds and the menus will automatically disappear.

RANGE - Automatic

When turned on for the first time, the X-70A automatically places the bottom signal in the lower half of the screen. This is called Auto Ranging and is part of the automatic function. The range cannot be changed while the unit is in automatic.

RANGE - Manual

The X-70A gives you control over the range when it's in the manual mode. There are two different methods used to change the range. The first way changes only the lower limit by pressing the arrow keys. On the screen shown below, the lower limit is 60 feet. The upper limit is zero. The second method lets you change both the upper and lower limits. This lets you create a "zoom" window down to five feet in virtually any combination of upper and lower limits. For example, a range with a 15 foot upper limit and a 45 foot lower limit creates a 30 foot zoom window. If the original range was zero to sixty feet, then this created a 2X zoom.

To change the range, first make certain the X-70A is in the manual mode. Next, press the RANGE key. The range adjustment menu appears on the right side of the display. To change only the lower limit, simply press the up or down arrow keys to decrease or increase the range. The available ranges are 0-5, 10, 20, 30, 40, 60, 100, 150, 200, 300, 500, 800, 1000, 1500, 2000, 3000, and 5000 feet. After the desired range is displayed, press the CLEAR key to erase the range menu.

NOTE: The maximum depth capability of the X-70A depends on the transducer installation, water and bottom conditions, and other factors. The performance of the X-70A will vary from day-to-day because of changing conditions.

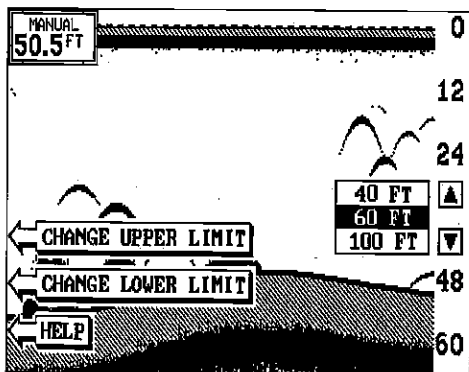
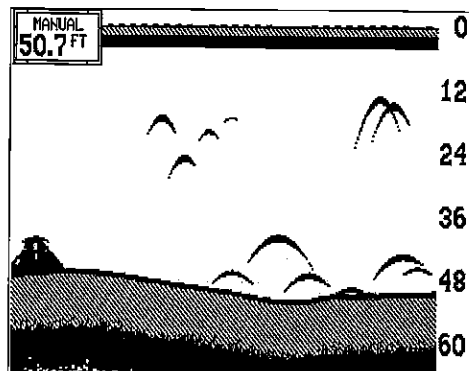

MENU - PAGE 2

ADJUST BACK LIGHT LEVEL

The X-70A has internal lights for the display and keyboard.

To adjust the intensity of the lighting, press the MENU key, then press the key adjacent to the "More" label. Now press the key next to the "Adjust Backlight Level" label. The screen shown below appears. Now

press the left arrow key to decrease the light level. Press the right arrow key to increase it. The percentage of back light in use changes as the arrow keys are pressed. The bar chart also gives a graphical indication of the level. After you've made the adjustment, press the CLR key to erase the menu.

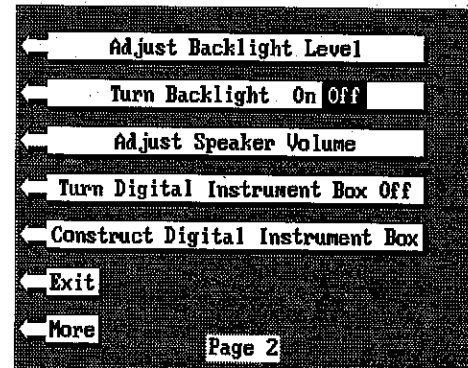

BACK LIGHT ON/OFF

To turn the back lighting on, first press the MENU key, then press the key next to the "More" label. Finally, press the key next to the "Turn Backlight On Off" label. This moves the black box from "OFF" to the "ON" position. To turn the backlights off, repeat the same steps.

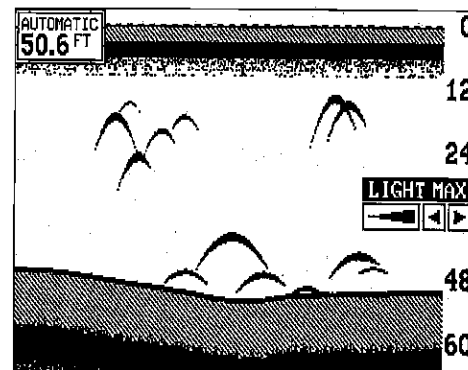

ADJUST SPEAKER VOLUME

The volume of the speaker's amplifier is adjustable. To change the volume, press the MENU key, then press the key adjacent to the "More" label. Now press the key next to the "Adjust Speaker Volume" label. A screen appears with the speaker volume adjust menu which is similar to the light adjust menu shown above. A musical tune sounds to indicate the current speaker volume. Now press the left arrow key to decrease the volume level. Press the right arrow key to increase it. The percentage of volume in use changes as the arrow keys are pressed. The bar chart also gives a graphical indication of the level. After you've made the adjustment, press the CLR key to erase the menu.

to distinguish from fish. You may see Fish I.D. symbols on the screen when actually, there are no fish. Practice with the unit in both the Fish I.D. mode and without to become more familiar with the Fish I.D. feature.

To turn the Fish I.D. feature on, press the menu key, then press the key adjacent to the "Turn Fish-ID Off On Fishtrack" label. Echoes will continue to scroll across the screen, however, the surface clutter at the top will no longer be displayed. Any targets the micro-computer determines are fish will be displayed as fish symbols. To turn the Fish I.D. feature off again, first press the menu key. Next, press the key adjacent to the "Turn Fish I.D. On Off Fishtrack" label until the box moves to the "Off" label. Press the CLR key to return to the sonar screen.

Remember, the Fish I.D. feature can't be used when the X-70A is in the manual mode. If you turn the Fish I.D. feature on when the X-70A is in manual, the micro-computer will turn the automatic feature on. If you turn automatic off when the Fish I.D. feature is on, the Fish I.D. feature will be turned off also.

FISHTRACK™

The FishTrack feature shows the depth of a fish symbol when it appears on the display. This lets you accurately gauge the depth of targets. This feature is available only when the Fish ID feature is on.

To turn the FishTrack feature on, press the menu key, then press the key adjacent to the "Fish-ID On Off FishTrack" label until the black box surrounds the "FishTrack" label. Echoes will continue to scroll across the screen, with the depth of fish symbols showing above them as they appear on the display. To turn the FishTrack feature off again, repeat the above steps, but move the black box to the "Off" position.

DISPLAY CONTRAST

The unit's display contrast is adjustable to suit different lighting conditions.

To adjust it, first press the menu key. The first menu page appears. Now press the key next to the "Adjust Display Contrast" label. A screen similar to the one below appears. Now press the left arrow key to decrease the contrast. Press the right arrow key to increase it. Press the CLR key to erase the menu.

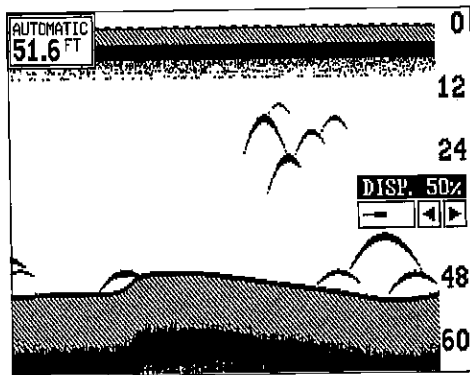

27

To change an upper or lower limit using the numbered keys, first press the RANGE key, then press the key next to either the "CHANGE UPPER LIMIT" or "CHANGE LOWER LIMIT" labels. On the screen shown at right, the key next to the "CHANGE UPPER LIMIT" was pressed. Now enter the desired depth, using the numbered keys. In this example, we entered 35 feet. Now press the ENT key. The X-70A erases the range menus from the screen, and uses the new range you entered as shown below.

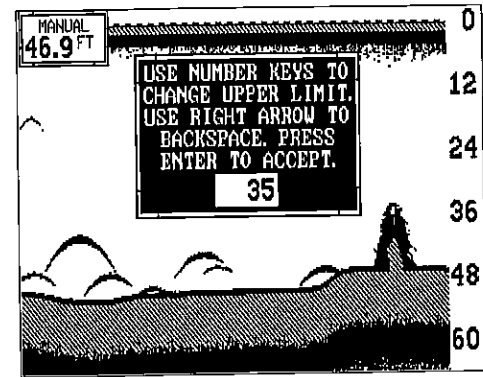

To change the lower limit, simply repeat the above steps, but press the key next to the "CHANGE LOWER LIMIT" label. Now enter the desired lower limit and press the ENT key. The X-70A erases the lower limit menus and changes the lower limit to the one you specified.

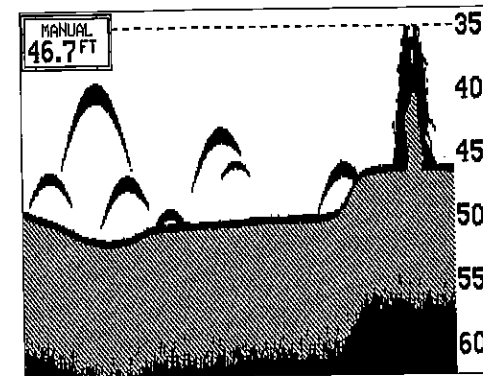

If you make a mistake while entering a limit, simply press the CLR key to erase the numbers. To exit from either the upper limit or lower limit entry screen, simply press the CLR key again.

ZOOM

Enlarging or "zooming" the picture is a common method used to show small detail and fish signals. The X-70A gives you two different zoom sizes, plus a split screen zoom option. The zoom operation and adjustment is different in the automatic and manual modes.

ZOOM - AUTOMATIC MODE

To zoom the display in the automatic mode, first press the ZOOM key. All targets on the display are enlarged four times normal size automatically. The menus shown at the top of the next page also appear.

20

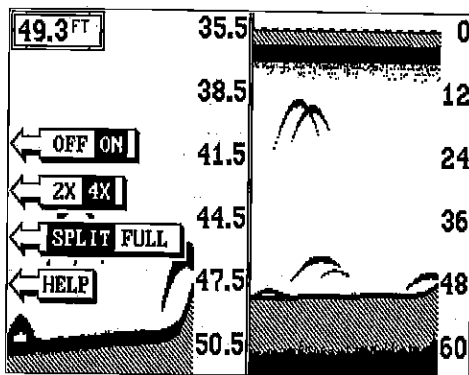

Turn the zoom feature on (or off) by pressing the key adjacent to the "OFF/ON" label.

Pressing the key adjacent to the "2X/4X" label enlarges echoes from two times to four times their normal size.

To switch between the split screen zoom and full screen zoom, press the key adjacent to the "SPLIT/FULL" label. The

screen instantly splits into two sections. All targets on the left are shown at four times the size of the ones on the right. If you switch to the 2X zoom mode, echoes on the left side of the screen are shown at twice the size as the ones on the right. The echoes that scroll across the screen are the exact same echoes on both sides of the screen. They're simply enlarged on the left side. This feature tracks the bottom, keeping it on the display at all times, when the automatic feature is on. Once you've set the zoom as desired, press the CLR key to erase the menus.

ZOOM - MANUAL MODE

When you press the zoom key while the unit is in the manual mode, the screen shown below appears. All of the menus on this screen work identically as described above. However, one additional menu item is shown when the unit is in the manual mode: "ADJUST".

To adjust the zoom, press the key adjacent to the "ADJUST" label. A screen similar to the one below appears. A zoom bar and adjust arrows appear on the screen. The echoes on the left side of the screen are the ones that appear between the top and the bottom of the zoom bar. Press the up or down arrow keys to move the zoom bar up or down. As you adjust the zoom bar, the echoes move on the left side of the screen at the same time. The zoom adjust menus will automatically clear a few seconds after you've pressed the last key. Remember, the X-70A won't track the bottom when it's in the manual mode.

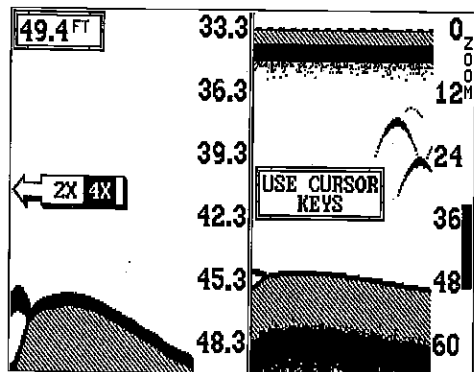

21



GRAYLINE® ON

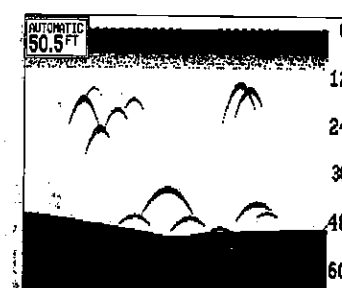

GRAYLINE® OFF

GRAYLINE level, also. The level chosen by the X-70A at power on is usually adequate for most conditions. Experiment with your unit to find the GRAYLINE setting that's best for you.

To adjust GRAYLINE, press the MENU key, then press the key adjacent to the "Adjust Chart Grayline" label. A screen similar to the one at right appears. Now press the left arrow key to decrease the gray level. Press the right arrow key to increase it. The percentage of GRAYLINE in use changes as the arrow keys are pressed. The bar chart also gives a graphical indication of the GRAYLINE level. You can see the change on the screen (both on the menu and on the chart record) as you press the keys. After you've made the adjustment, press the CLR key to erase the menu.

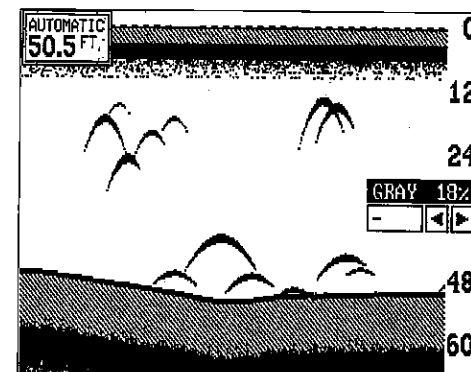

FISH I.D.

The Fish I.D. feature identifies targets that meet certain conditions as fish. The micro-computer analyses all echoes and eliminates surface clutter, thermoclines, and other signals that are undesirable. In most instances, remaining targets are fish. The Fish I.D. feature displays symbols on the screen in place of the actual fish echoes. There are four fish symbol sizes: tiny, small, medium, and large. These are used to designate the relative size between targets. In other words, it displays a small fish symbol when it thinks a target is a small fish, a medium fish symbol on a larger target, etc.

The micro-computer is sophisticated, but it can be fooled. It can't distinguish between fish and other suspended objects such as trotlines, turtles, submerged floats, air bubbles, etc. Individual tree limbs extending outwards from a group of limbs is the hardest object for the Fish I.D. feature

26

MENU - PAGE 1

CHART SPEED

The rate echoes scroll across the screen is called the chart speed. It's adjustable by first pressing the menu key, then pressing the key adjacent to the "Adjust Chart Speed" label. The chart speed menu appears on the right side of the screen. Increase the chart speed by pressing the right arrow key or decrease it by pressing the left arrow key.

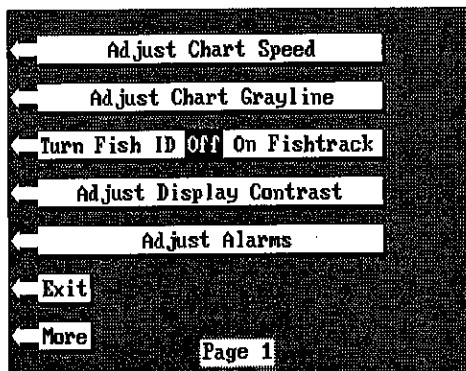

The percentage of chart speed in use changes as the arrow keys are pressed. The barchart also gives a graphical indication of the chart speed. You can see the change on the screen (both on the menu and on the chart record) as you press the keys. After you've made the adjustment, press the CLR key to erase the menu.

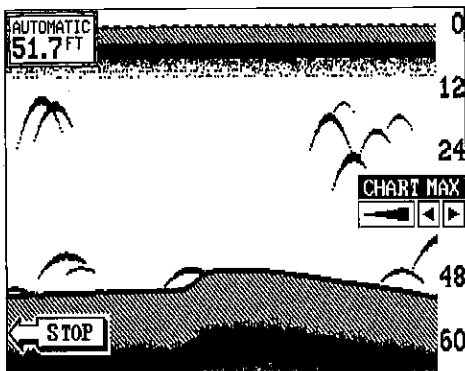

To stop the chart, press the key adjacent to the "STOP" label in the unit's lower left corner. To

start the chart, press the key next to the "START" label.

GRAYLINE®

GRAYLINE lets you distinguish between strong and weak echoes. It "paints" gray on targets that are stronger than a preset value. This allows you to tell the difference between a hard and soft bottom. For example, a soft, muddy or weedy bottom returns a weaker signal which is shown with a narrow or no gray line. A hard bottom returns a strong signal which causes a wide gray line.

If you have two signals of equal size, one with gray and the other without, then the target with gray is the stronger signal. This helps distinguish weeds from trees on the bottom, or fish from structure.

GRAYLINE is adjustable. Since GRAYLINE shows the difference between strong and weak signals, adjusting the sensitivity may require a different

ALARMS

The X-70A has three different types of sonar alarms. The first is the Fish Alarm. It sounds when the Fish I.D. feature determines an echo or group of echoes is a fish. Another alarm is the Zone Alarm which consists of a bar. Any echo that appears inside this bar triggers the alarm. The last alarm is called the Depth Alarm. Only the bottom signal will trigger this alarm. This is useful as an anchor watch, a shallow water alert, or for navigation.

To adjust an alarm, first press the MENU key. Now press the key next to the "Adjust Alarms" label. The screen shown below appears. Press the key next to the "SET DEPTHALARMS" to adjust the shallow or deep digital alarms. Press the key next to the "SET ZONE ALARM" to adjust the zone alarm. The fish alarm doesn't have an adjustment. It's either on or off.

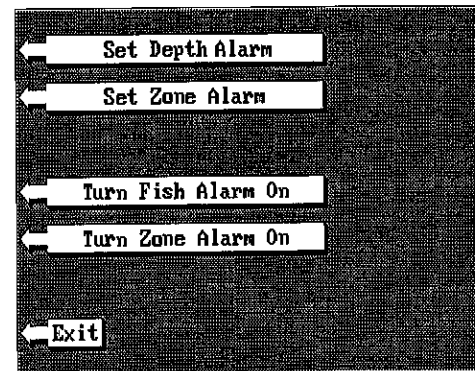

The following section describes each sonar alarm and its limits.

FISH ALARM

Use the fish alarm for a distinctive audible alarm when fish or other suspended objects are detected by the Fish I.D. feature. A different tone sounds for each fish symbol size shown on the display.

To turn the fish alarm on, press the MENU key, then press the key next to the "Adjust Alarms" label. The screen shown above appears. Now press the key next to the "Turn Fish Alarm On" label.

To turn the fish alarm off, repeat the above steps. The label on the Alarms menu now reads "Turn Fish Alarm Off". Press the key next to that label to turn the fish alarm off.

DEPTH ALARMS

The depth alarms sound a tone when the bottom signal goes shallower than the shallow alarm's setting or deeper than the deep alarm's setting. For example, if you set the shallow alarm to ten feet, the alarm will sound a tone if the bottom signal is less than ten feet. It will continue to sound until you mute it or until the bottom goes deeper than 10 feet. The deep alarm works just the opposite. It sounds a warning tone if the bottom depth goes deeper than the alarm's setting. Both depth alarms work only off the digital bottom depth signals. No other targets will trip these alarms. These alarms can be used at the same time or by themselves.

To set the depth alarms, first press the MENU key, then press the key next to the "Adjust Alarms" label. The screen on the previous page appears. Now press the key next to the "Set Depth Alarms" label. The screen at the top of this page appears.

To adjust the shallow alarm, press the key next to the "Shallow" label. To adjust the deep alarm, press the key next to the "Deep" label. Both alarms

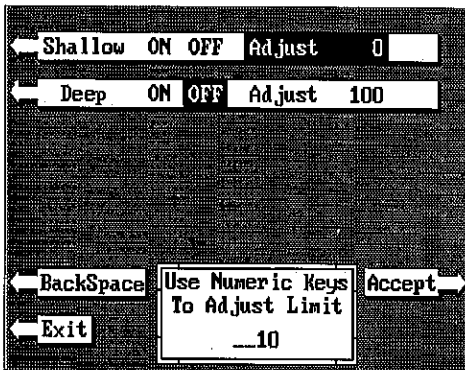

adjust identically. We'll use the shallow alarm as an example. Pressing the key next to the "Shallow" label moves the black box from the "OFF" position to the "Adjust". A new screen appears as shown at right. Use the numbered keypad on the right side of the unit to enter the shallow alarm setting. We used 10 feet in this example. After you've entered the desired alarm depth, press the ENT key. This enters the alarm

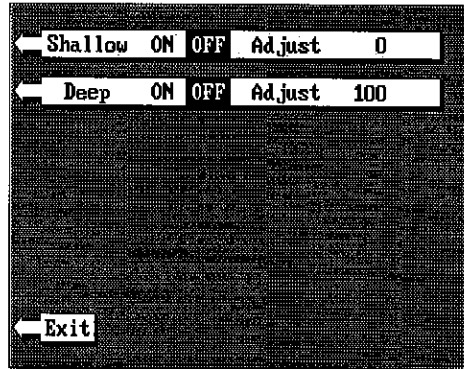

ZONE ALARM

The zone alarm consists of a bar that appears on the right side of the screen. Any echo that appears on the screen between the top and bottom of the zone alarm's bar will "trip" the zone alarm.

Note: The zone alarm isn't available in the Windows mode.

To set the zone alarm, press the MENU key. Now press the key next to the "Adjust Alarms" label. Finally, press the key next to the "Set Zone Alarm" label. A screen similar to the one shown below appears.

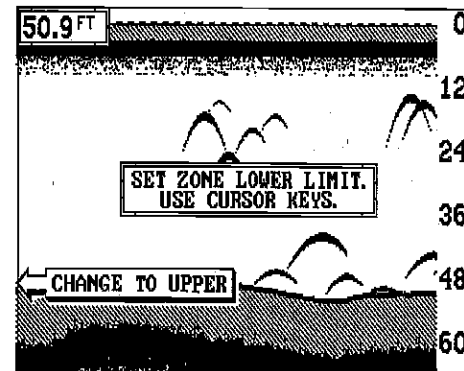

The zone alarm bar shows on the right side of the screen. Use the arrow keys to move the bottom of the bar higher or lower. To move the top of the bar, first press the key next to the "CHANGE TO UPPER" label. Now use the arrow keys to move the top of the bar higher or lower. When you have the zone alarm bar set as desired, press the CLR key to erase the menus.

The above steps automatically turn the zone alarm on if it was off. To turn the zone alarm off, press the MENU key, then press the key next to the "Adjust Alarms" label. Now press the key next to the "Turn Zone Alarm Off" label at the bottom of the screen.

Normally, the zone alarm bar disappears from the screen after you make adjustments. To leave the zone alarm bar on the screen all of the time, see the "Display Zone Alarm Bar" section in this manual for instructions.

